

1 2 3 4 5 6 7 8

REVISIONS				
REV	ZONE	DESCRIPTION	DATE	APPROVED

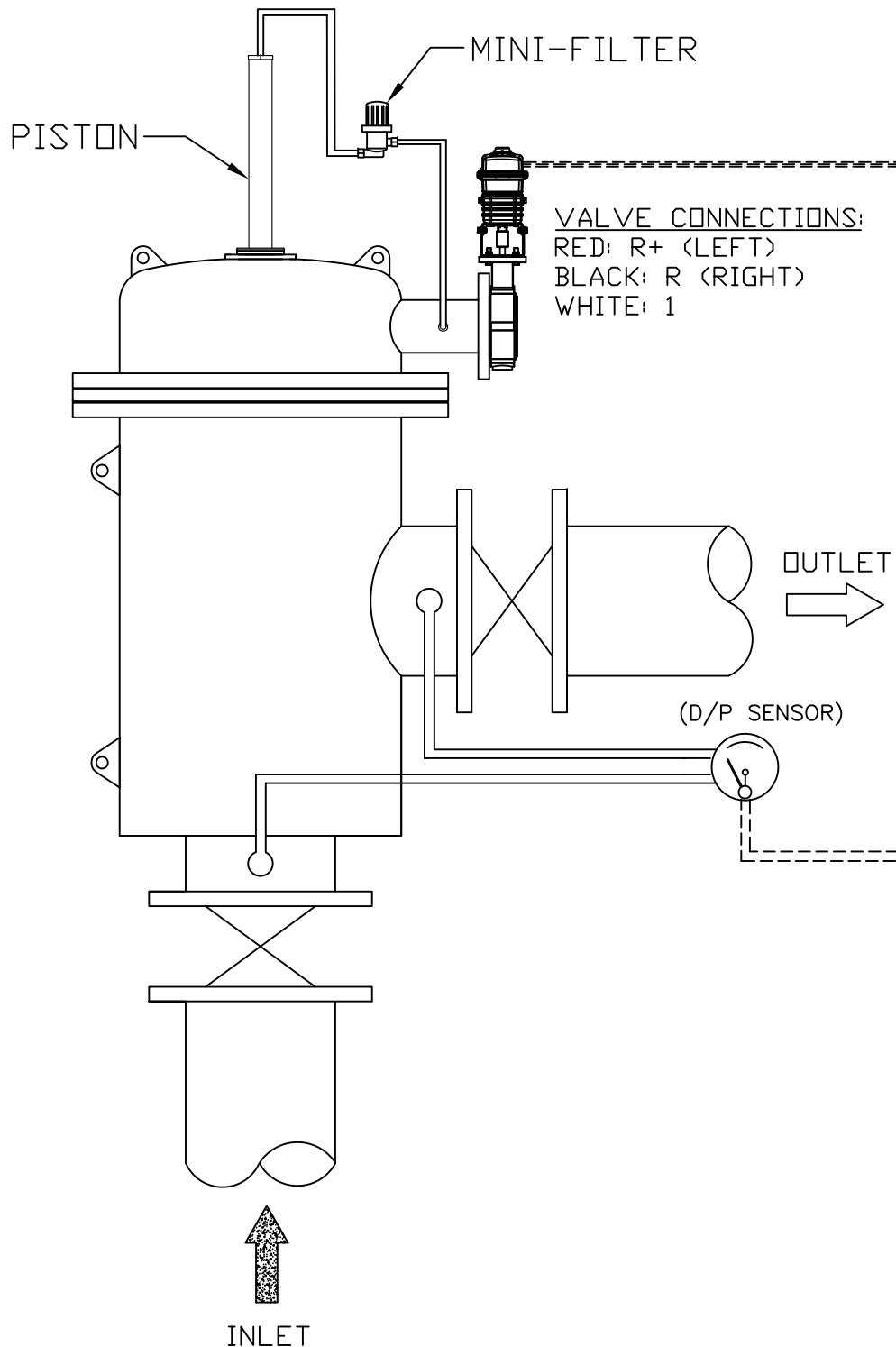

VALVE CONNECTIONS:  
 RED: R+ (LEFT)  
 BLACK: R (RIGHT)  
 WHITE: 1

### GB6 ELECTRIC CONTROLLER

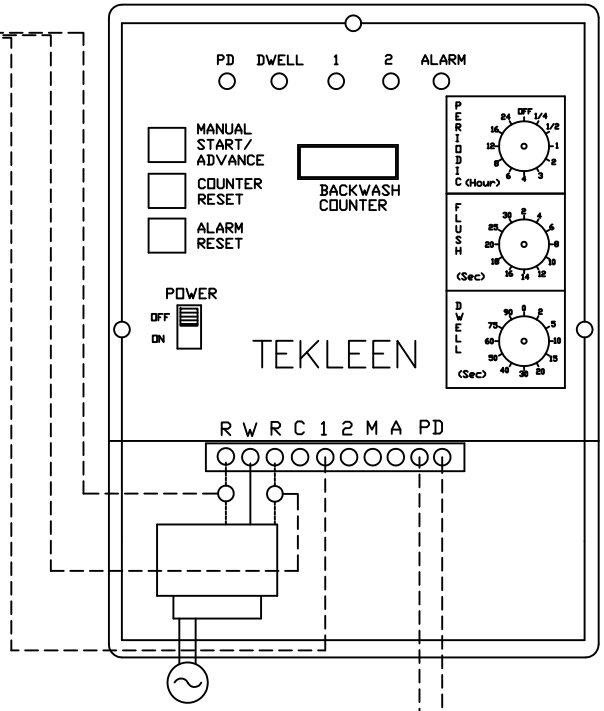

UNLESS OTHERWISE SPECIFIED DIMENSIONS ARE IN INCHES TOLERANCES		AUTOMATIC FILTERS, INC. 2672 S. LA CIENEGA BLVD. LOS ANGELES, CA 90034 (310) 839-2828 FAX (310) 839-6878		
DECIMALS .XX ± .05 .XXX ± .01		ANGULAR ± 0.5 DEG.		
DRAWN S. PERKINSON	DATE 02/08/12	TITLE WIRING LAYOUT FOR LARGE MTF FILTER WITH GB6 ELECTRIC CONTROLLER & ELECTRIC BUTTERFLY FLUSH VALVE		
CHECKED		SIZE A	DWG NO. WIRE-MTFGB6-EBFV-LAY-01	REV N/A
DESIGN FOR:		NOT TO SCALE		SHEET 1 OF 1