

AUTOMATIC FILTERS, INC.

2672 S. LA CIENEGA BLVD.
LOS ANGELES, CA 90034
310 839 2828 800 336 1942
FAX 310 839 6878
www.Tekleen.com
info@Tekleen.com

ABW USERS'
MANUAL

Tekleen

Check List for Optimal Filter Performance

- ? There should be no back-pressure on the flush line. A 1" valve should have a 2" waste line, and 2" valve should have a 3" waste line. Do not use rubber hosing or flexible tubing for the waste line.
- ? The differential pressure gauge should be mounted within 3 feet of the filter. Long tubing lines will result in faulty gauge readings.
- ? The water supply line to the piston should be connected to the neck of the flush outlet and filtered by a 1/4" mini filter.
- ? The fitting on the side of all pistons is for venting only. It should be open to atmospheric pressure and pointing toward the ground.
- ? Sealant should be applied on the contact points on the backside of the d/p gauge to protect it from water. The d/p gauge should be mounted up-side down to prevent shorting of the contact points in the event of a water leak.
- ? If the filter outlet discharges to a tank, or to open atmosphere, a valve should be installed at the filter outlet to maintain a minimum working pressure of 40 PSI during the cleaning cycle.
- ? If the flush valve fails to open or close, verify the connections to the controller are wired correctly (see diagram on pg. 15).
- ? A surge protector should be installed before the electronic controller.

To ensure proper installation, email digital pictures with contact information to info@tekleen.com before startup.



AUTOMATIC FILTERS, INC.

Tekleen®

2672 S. LA CIENEGA BLVD.
LOS ANGELES, CA 90034
310 839 2828 800 336 1942
FAX 310 839 6878
www.Tekleen.com
info@Tekleen.com

Table of Contents

<u>SECTION I INTRODUCTION</u>		
1.1	Description	1
1.2	Theory of Operation	1
1.3	Recommended Applications	2
1.4	Design Features	2
1.5	Filter Specification Chart	3
<u>SECTION II INSTALLATION AND HOOK-UP</u>		
2.1	Mechanical Hook-Up and Orientation	4
2.2	Plumbing Hook-Up	4
2.3	GB6, DP Gauge, and Electric Ball Valve Connection	4
<u>SECTION III OPERATION AND ADJUSTMENTS</u>		
3.1	Start-up	5
3.2	Cleaning Cycle Requirements	6
<u>SECTION IV MAINTENANCE</u>		
4.1	Shutdown Procedure	7
4.2	Filter Cleaning	8
4.3	Dirt Collector Replacement	8
4.4	Piston Removal/Replacement	8
4.5	Periodic Inspection	9
<u>SECTION V TROUBLESHOOTING GUIDE</u>		
5.1	Excessive pressure drop through filter without flushing	9
5.2	Frequent or continuous flushing while filling main pipeline	9
5.3	Frequent flushing during normal operation	10
5.4	Screen Will Not Clean Properly	10
<u>SECTION VI SPARE PARTS</u>		
6.1	Recommended Spare Parts	10
6.2	Spare Parts List	11
<u>APPENDICES</u>		
Appendix I	Special Installation	12
Appendix II	Alternate Flushing Methods	12
Appendix III	System with Discharge to Atmosphere	13
Appendix IV	Piston	14
<u>ILLUSTRATIONS</u>		
	ABW Installation Layout with GB6 and Electric Flush Valve	15
	Cutaway of ABW2-LP	16
	Cutaway of ABW3-4	17
	Cutaway of ABW4L-6L-8	18
	Cutaway of ABW6xL-8L-8L-12-14-16	19
	ABW 2LP with GB6 Controller	20
	ABW 3-4 with GB6 Controller	21
	Particulate Removal Process	22
	Pressure Drop vs. Screen Size	23
	Filter Warranty	24

SECTION I INTRODUCTION

1.1 Description

The ABW series features a automatic, self cleaning screen type water filters. The filtration system consists of a filter body with a first stage coarse screen and a second stage fine screen, a flushing valve, and an electronic controller.

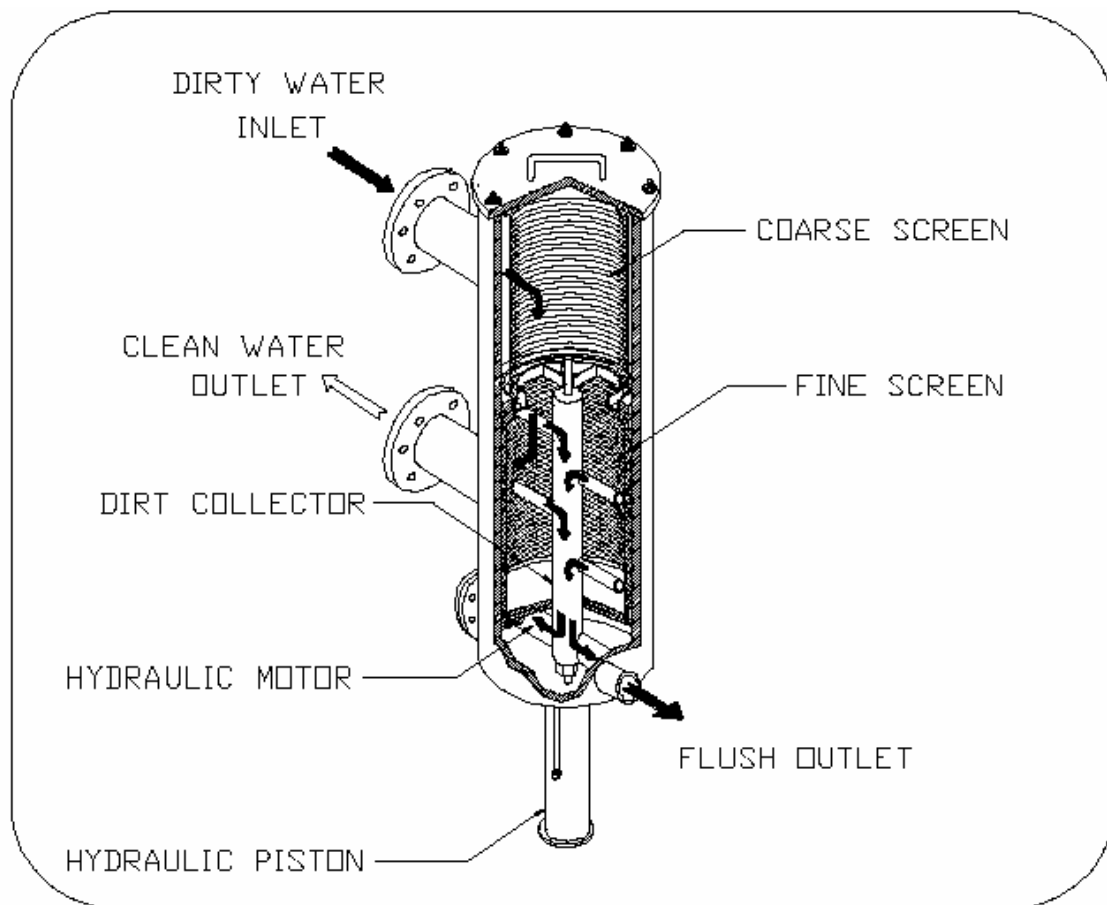

1.2 Theory of operation

Pressurized water enters the filter inlet and travels through a 3/8" perforated stainless steel coarse screen (1/4" for smaller models) where large particles are pre-filtered. The water then passes through a fine mesh stainless steel screen where small contaminants (down to 10 microns in size) are filtered out. The clean water then exits through the outlet of the filter.

When the fine screen becomes contaminated, a pressure differential is sensed causing the automatic controller to open the flush valve. When the flush valve opens, an atmospheric pressure path is established, causing the clean water to reverse flow at the point of suction across the filter element. This process

removes contaminants from the screen, sending the dirty water through the nozzles and the dirt collector mechanism and out the flush valve.

The water passing through the hydraulic motor creates an axial rotation of the dirt collector. This movement, combined with linear advancement, allows the dirt collector to vacuum the entire screen element.

The entire cleaning cycle takes approximately 4-12 seconds. It should be noted that even during the flush cycle, the filtration process continues uninterrupted.

1.3 Recommended Applications

Tekleen ABW water filters are ideal for filtering out silt, scale, sand, rust, dirt and organic material like algae, zebra mussels, and clams from virtually all types of water sources.

1.4 Design Features

Among the many features of the ABW models is an avoidance of forcing contaminated water back into the system, which often happens with sand media filters. ABW filters will deliver clean water or no water at all.

The most predominant feature is its ability to remove organics such as algae and other suspended particles.

All internal elements can be removed and disassembled from the filter body without disruption of the plumbing.

The backwash cycle, Tekrinse, uses 90% less rinse water than other filters on the market today.

For special constructions and applications, see Appendix I, page 12.

1.5 Filter Specifications Chart

Model	Flange Size	Screen Area	Max. Flow	Empty Weight	Service Area
	Inch	Sq. Ft.	GPM	Lbs.	Inch
ABW2-L	2	0.5	130	120	7
ABW2-LP	2	0.5	130	120	7
ABW2-S	2	1.4	200	150	13
ABW2-SP	2	1.4	200	150	13
ABW3	3	0.5	150	125	7
ABW3-S	3	1.4	200	150	13
ABW3-SP	3	1.4	200	150	13
ABW3-LP	3	2.5	300	180	20
ABW4	4	1.4	300	170	13
ABW4-P	4	1.4	300	170	13
ABW4-LPE	4	2.5	400	180	20
ABW4-L	4	5	500	230	35
ABW4-LP	4	5	500	230	35
ABW4-XLP	4	8	800	400	51
ABW4-SP	4	7	1,000	500	62
ABW6-P	6	2.5	600	180	20
ABW6-L	6	5	800	280	35
ABW6-LP	6	5	800	280	35
ABW6-XLP	6	8	800	400	51
ABW6-TXLP	6	16	1,500	900	51
ABW6-SP	6	7	1,750	400	62
ABW8	8	5	1,320	400	35
ABW8-P	8	5	1,320	300	35
ABW8-LP	8	8	1,500	450	51
ABW8-SP	8	7	1,750	500	62
ABW8-TLP	8	16	2,500	1,000	51
ABW10	10	7	1,750	500	62
ABW10-P	10	7	1,750	500	62
ABW10-LP	10	11	2,630	650	91
ABW12	12	11	2,630	700	91
ABW12-P	12	11	2,630	700	91
ABW12-LP	12	12.5	4,000	800	91
ABW14	14	12.5	4,000	800	91
ABW14-P	14	12.5	4,000	800	91
ABW14-LP	14	16	6,000	1,000	91
ABW16-P	16	12.5	5,000	900	91
ABW16-LP	16	16	6,000	1,000	91
ABW16-L	16	16	6,000	1,000	91
ABW16-SP	16	24	10,000	1,400	91
ABW18-TP	18	25	8,000	1,600	91
ABW18-SP	18	24	10,000	1,800	91
ABW20-TP	20	25	8,500	2,000	91
ABW20-SP	20	24	10,000	2,500	91
ABW20-TLP	20	32	10,000	1,800	91
ABW24-SP	24	24	10,000	2,500	91
ABW24-TLP	24	32	12,000	2,000	91
ABW30-TSP	30	48	10,000	2,500	91
ABW36-TSP	36	48	20,000	2,800	91

SECTION II INSTALLATION AND HOOK-UP

2.1 Mechanical Hook-Up and Orientation

The positioning of the filter tank should be determined by the disposal of waste water and to allow easy access and removal of filter element (see Filter Specifications Chart for the required service area). The Tekleen filter can rest on the inlet and outlet flanges or can be mounted on a stand if desired. In fact, the filter can be mounted in any position (vertical, upside down, etc.). The electronic controller should be mounted in close proximity to the filter housing.

2.2 Plumbing Hook-Up

The waste discharge pipe should be at least one inch larger in diameter than the size of the flush valve (1" valve to 2" pipe & 2" valve to 3" pipe). The waste pipe should be kept as short as possible with no more than one elbow. This will minimize back pressure on the flush line.

Flush lines should not be elevated. This will affect the pressure difference required for the cleaning cycle. If it is necessary to run flush lines uphill, please consult with the manufacturer.

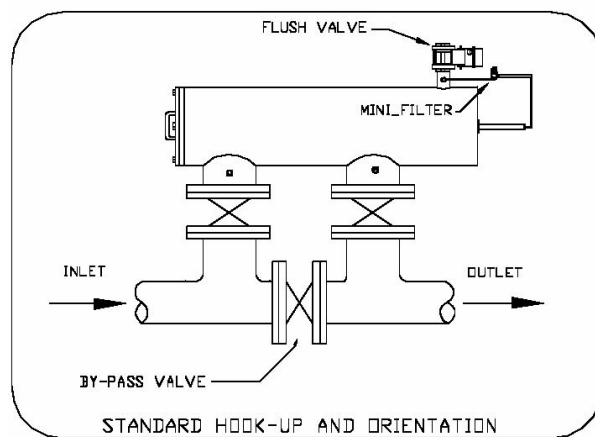

Flush line pipe must be ridged. It should not be made out of flexible tube or rubber hosing. Any restrictions in the flush line will reduce the cleaning ability of the filter.

A block valve should be installed at the inlet of the filter. During start-up, the block valve should be only slightly open to prevent a surge of pressure across the filter when the pump is started. Once the pump is on-line, slowly open the block valve. This will prevent any possible damage to the filter due to a pressure surge.

2.3 GB6, DP Gauge, and Electric Ball Valve Connection

Before power is applied to the electronic controller, make all connections between the controller, DP Gauge, and electric ball valve (see page 14).

1. BALL VALVE: Plug controller into appropriate power source. Connect the ball valve to the controller as shown in the wiring diagram (page 14). Activate the manual start switch on the GB6 controller and visually inspect the open and close movement of the ball valve.

2. **FLUSHING TIME ADJUSTMENT:** The flush time is normally set to 8 seconds. Flush time should be adjusted to allow the piston indicator pin to reach the end of the slot during one backwash cycle. **NOTE:** Excessive flush time will not improve cleaning, and may lead to unnecessary wear and tear on filter equipment.

3. **PRESSURE DIFFERENTIAL ADJUSTMENT:** The differential switch is preset for 7 PSI. It can be changed to different set points (see your electronic controller manual).

USING 1/4 INCH DIAMETER TUBING

1. Attach tubing to the low pressure ¼” fitting (on the outlet flange). Attach the other end of the tubing to the fitting on the DP switch marked “low” pressure.

2. Attach tubing to the high pressure ¼” fitting (on the inlet flange). Attach the other end of the tubing to the fitting on the DP switch marked “high” pressure.

Notes: Do not run tubing more than three feet in length (preferably two feet or less). Due to the pressure drop across the tubing, the electronic controller may not operate properly if tubing is too long.

3. Attach tubing to the end of the piston. Attach the other end to the fitting on the neck of the flush outlet (before the flush valve). The mini-filter should be added to this ¼” line to prevent larger debris particles from plugging the piston. The fitting on the side of the piston should point downward and be used to vent the piston (see appendix IV pg. 14).

SECTION III OPERATION AND ADJUSTMENTS

3.1 Start-Up

During start-up, the block valve at the filter inlet should be only partially open to prevent a surge of pressure across the filter when the pump is started. Once the pump is on-line, slowly open the block valve. This will prevent any possible damage to the filter due to a pressure surge.

During the initial filling of the main pipeline, there may not be enough back-pressure downstream from the filter to allow the cleaning cycle to function properly. Therefore, it is necessary to install a valve at the outlet to be partially closed (i.e., gate valve, ball valve or butterfly valve).

If a downstream main line valve is partially closed, enough to provide 40 PSI at the filter inlet pressure gauge, the self cleaning cycle will operate properly. Once the total system is fully charged, the downstream valve can be adjusted, as long as 40 PSI is maintained at the filter inlet during the cleaning cycle.

In applications where the main flow to the filter is intentionally interrupted and the line is drained, it is advisable to install a flow control or pressure sustaining valve downstream from the filter. This will create back pressure on the filter in order to enable proper flushing while main line pressurizes.

Once the system is fully pressurized, push the manual flush button on the electronic controller, and verify that the piston is moving and the flush valve is opening all the way. During the first cleaning cycle, air in the system will be expelled, so it may require more than one cycle to achieve proper cleaning.

3.2 Cleaning Cycle Requirements

WORKING PRESSURE

The filter requires a minimum pressure of 40 PSI at the inlet during the cleaning cycle for effective cleaning.

Maintaining the necessary minimum working pressure during the cleaning cycle requires a pump with sufficient capacity. Pump selection will depend on three key parameters: the required working pressure (40 PSI), the process flow of the system, and the flush flow of the filter.

PROCESS FLOW

Process flow is the volumetric rate of water that will pass through the filter during normal operation (when the filter is not in a cleaning cycle).

FLUSH FLOW

The flush flow is the volumetric rate of water that will be used during a cleaning cycle. This rate depends on the size of the flush valve used.

FLUSH VALVE SIZE		FLUSH FLOW at 40 psi	
Inch	mm	gpm	m ³ /hr.
1"	DN25	40	9
2"	DN50	160	36

To determine if a pump will satisfy the performance needs of your system, add the process flow of the system to the flush flow of the filter to find the total flow.

$$\text{Process Flow} + \text{Flush Flow} = \text{Total Flow}$$

Consult the pump curve provided by the pump manufacturer to determine if it meets the performance requirements. The pump curve describes the performance of the pump in terms of flow and pressure. Locate your total flow on

the graph to determine what pressure will be maintained at that flow. If the pressure is greater than 40 PSI, then the pump satisfies the requirements.

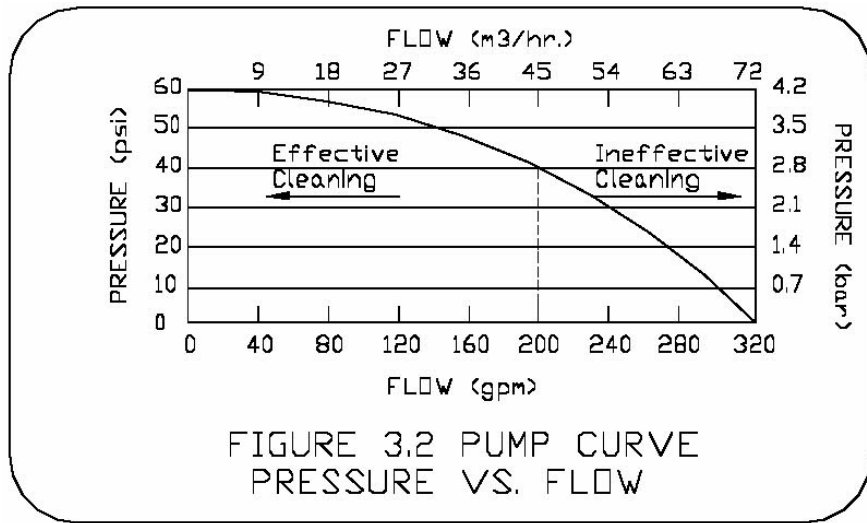

Figure 3.2 shows an example of a pump curve. Since a minimum of 40 PSI must be maintained, the critical point for this pump is at 200 gpm. Any flow greater than this will not yield effective cleaning during the backwash cycle.

If, for example, the process flow were to be 190 gpm and the flush flow 40 gpm, the total flow would be 230 gpm. This would produce an inlet pressure less than the required 40 PSI and as a result the filter would not be able to perform an effective cleaning cycle.

If the process flow were to be 150 gpm with a flush flow of 40 gpm, the total flow would be 190 gpm. This would produce an inlet pressure greater than the required 40 PSI and result in an effective cleaning cycle.

SECTION IV MAINTENANCE

4.1 Shutdown Procedure

When shutting down the filter, steps must be taken to ensure that there will be no reverse flow across the screen that may damage components. The proper shutdown sequence is as follows:

1. Open the bypass valve.
2. Close the outlet valve completely.
3. Close the inlet valve completely. The filter is now isolated and the system flow is bypassed.
4. Relieve any residual pressure in the filter housing by detaching the 1/4" plastic tubing from any fitting.

5. Drain the remaining water from the filter body by either:
 - a. Unscrewing the 1" NPT pressure release plug (located on the top and bottom of the filter).
 - b. Loosen the cover nuts and slightly open the cover.

4.2 Filter Cleaning

The coarse screen is not part of the self cleaning mechanism. Therefore periodic cleaning and inspection of the coarse screen, if supplied, is necessary for removal of large particles trapped in the chamber. To do this, simply follow the shutdown procedure, and then remove the filter cover.

It is also recommended that the fine screen be inspected during coarse screen cleaning. For models with line sizes of 2"-8", remove fine screen using screen installer/remover tool.

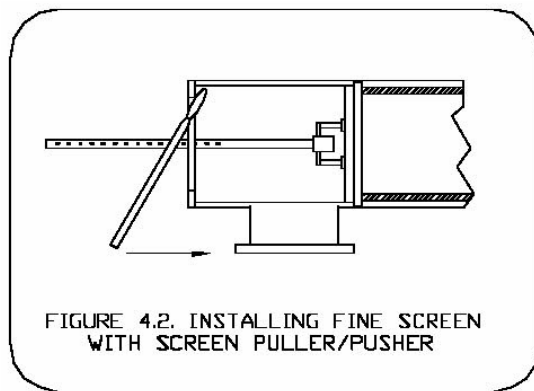
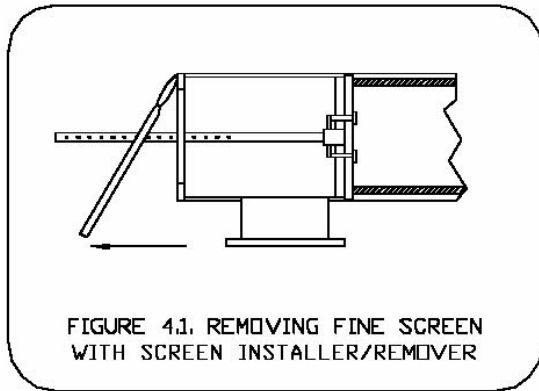

4.3 Dirt Collector Replacement

If the dirt collector should ever need replacing, follow steps 1 through 5 in section 4.1 (Shutdown Procedure) and proceed as follows:

1. Open the service port flange.
2. Unscrew the lower bearing.
3. Remove the hydraulic motor.
4. Remove the dirt collector.

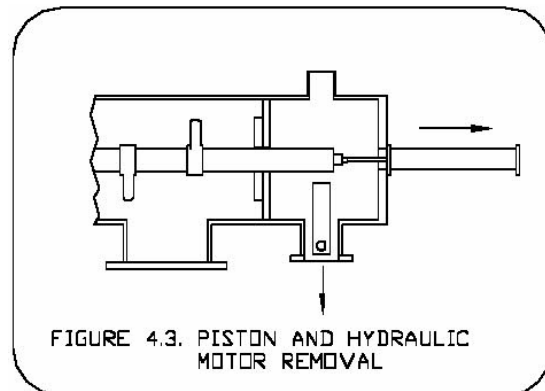

4.4 Piston Removal/Replacement

If the piston needs to be removed or replaced, follow the steps outlined and refer to Fig. 4.3:

1. Follow steps 1-5, section 4.1

2. Unscrew all connection nuts.
3. Remove piston from the filter housing.
4. Re-assemble unit (reverse procedure).

4.5 Periodic Inspection

The following parts should be inspected annually for wear and tear and should be replaced if necessary:

- | | |
|------------------|--------------------------|
| - Cover Seal | - Coarse Screen |
| - Fine Screen | - O-rings |
| - Piston | - Dirt Collector Nozzles |
| - Dirt Collector | - Upper Bearing |
| - Lower Bearing | - Air/Water Connections |

SECTION V TROUBLESHOOTING GUIDE

5.1 Problem: Excessive pressure drop through filter without flushing.

POSSIBLE CAUSES

1. Controller is not turned on.
2. Flush valve is wired incorrectly.
3. Filter is installed backwards.
4. D/P switch is malfunctioning.

SOLUTIONS

1. Turn the power switch to "on".
2. Consult the wiring diagram, and verify that the valve is connected correctly.
3. Verify correct flow through filter.
4. Check set point on D/P switch. Make sure ¼" black tubing is less than 3 feet in length and unobstructed. Verify that the D/P switch is connected to the appropriate fittings on the filter.

5.2 Problem: Frequent or continuous flushing while filling main pipeline.

POSSIBLE CAUSES

1. Downstream pressure is not available to provide effective cleaning cycle.
2. High flow rate exceeds the D/P switch's preset differential.
3. Filter may have been shut down while the screen is dirty, resulting in a layer of contaminant on the screen that has caked on.

SOLUTIONS

- 1&2. Partially close downstream mainline valve. Filter inlet gauge should read at least 40 PSI.

3. A “super flush” must be performed as follows: Close the outlet valve and initiate a cleaning cycle. Open the outlet valve and check the filter differential. If the differential does not return to zero, repeat the process.

5.3 Problem: Frequent flushing during normal operation.

POSSIBLE CAUSE

1. Very dirty water.
2. Marginal working pressure results in poor cleaning cycle.
3. Screen may be partially plugged.
4. Dirt collector may be jammed which results in only cleaning the screen directly in front of the nozzles.

SOLUTION

1. Screen opening size may be too small for the given application. Consult manufacturer.
2. Verify the inlet pressure is at least 40 PSI during the cleaning cycle. If not, partially close the outlet valve to increase inlet pressure.
3. Perform super flush as described in section 5.2.
4. Open filter and verify the dirt collector rotates freely.

5.4 Problem: Screen will not clean properly.

POSSIBLE CAUSE

1. The flush cycle duration is too short.
2. Filter was shut down dirty with contaminants caked on the screen.
3. Flush line is causing back pressure on the flush valve.
4. Piston is not operating properly.

SOLUTION

1. Increase flush duration on controller panel.
2. Perform super flush as described in section 5.2.
3. Make sure the flush line is 1” larger than the flush valve (See section 2.2).
4. Verify that the indicator pin is moving during the cleaning cycle. Make sure that the inlet pressure is at least 40 PSI during the cleaning cycle.

SECTION VI SPARE PARTS

6.1 Recommended Spare Parts

The following are recommended spare parts to keep in stock:

- | | |
|--------------------------|------------------------------|
| - Fine Screen (4) | - Set of O-rings (16) |
| - Cover Seal (10) | - Dirt Collector (5) |
| - Upper Bearing (11) | - Lower Bearing (12) |
| - D/P Switch (34) | - Controller Board |
| - Piston Repair Kit (29) | - Dirt Collector Nozzles (6) |
| - Mini-Filter (18) | |

6.2 Spare Parts List

PART NUMBERS ARE DESIGNATED WITH FILTER MODEL NUMBER. FOR EXAMPLE, THE PART NUMBER FOR A FINE SCREEN FOR AN ABW 4-LP IS 4-ABW4-LP

4 IS THE PART NUMBER FOR A FINE SCREEN.

ABW 4-LP IS THE FILTER MODEL.

1. FILTER HOUSING
2. COVER
3. COARSE SCREEN
4. FINE SCREEN
5. DIRT COLLECTOR
6. DIRT COLLECTOR NOZZLE
7. HYDRAULIC MOTOR
8. FLUSH VALVE ASSEMBLY
10. COVER SEAL
11. UPPER BEARING
12. LOWER BEARING
13. SCREEN HANDLE
15. COLLECTOR PIN
16. UPPER/LOWER O-RING
17. FLUSH VALVE ACTUATOR
18. MINI-FILTER (OPTIONAL)
19. BUSHING ASSEMBLY
20. COVER NUT
22. HYDRAULIC PISTON 1.5" OR 2" SHORT / LONG
23. COVER WASHER
24. COVER STUDS
25. SET OF FITTINGS
27. PRESS. SUSTAIN. VALVE (N. S.)
29. PISTON REPAIR KIT (N. S.)
30. SCREEN INSTALLER/REMOVER N. S.
31. PISTON GUARD
34. DIFF. PRESS. SWITCH (N. S.)
35. PSV DIAPHRAGM (N. S.)
37. ELECTRONIC CONTROLLER (N. S.)
41. PSV ACTUATOR (N. S.)

N. S. - NOT SHOWN

UNLESS OTHERWISE SPECIFIED DIMENSIONS ARE IN INCHES TOLERANCES		AUTOMATIC FILTERS, INC. 2672 S. La Cienega Blvd. Los Angeles, CA 90034 (310) 839-2828 Fax: (310) 839-6878	
DECIMALS .0005		ANGULAR ± .05 DEG.	
XXX ± .01			
DRAWN Daniel Stenberg		DATE 1-8-07	
CHECKED		TITLE PARTS LIST FOR ABW w/ PISTON	
DESIGN		SIZE A	DWG NO. TKLN AF-PARTS-02
		REV 0	SHEET 1 OF 1

APPENDICES

Appendix I Special Installation

I. AUTOMATIC BY-PASS

Sometimes it is necessary to have flow even when the filter is out of service for periodic maintenance. In this situation, it is recommended to create a by-pass.

FILTER BY-PASS

It is very simple to create a by-pass, especially for the on-line models. To do so, add a block valve on both the inlet and outlet and a bypass with another block valve (see drawing).

If the by-pass valves are provided with actuators, it can be converted into an automatic by-pass system by wiring them to the controller (see controller manual).

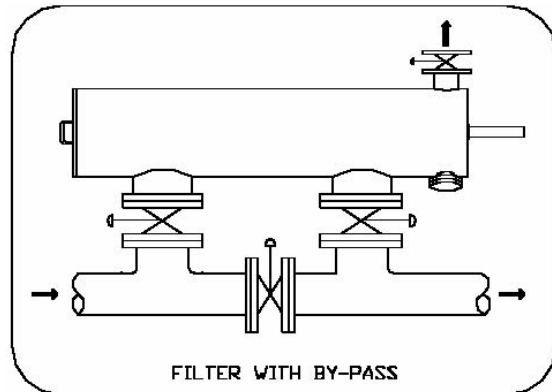

Appendix II Alternate Flushing Methods

There are several possible solutions if there is not enough pressure and/or flow to successfully achieve a backwash. For low flow installations with pressure greater than 40 PSI, proceed as follows:

1. The easiest method is to place an automatic valve (pressure sustaining valve) at the filter outlet. The valve will close when the filter is flushing. During the cleaning cycle, there would be no water available to the system and the full pump capacity will be used for the backwash filter.

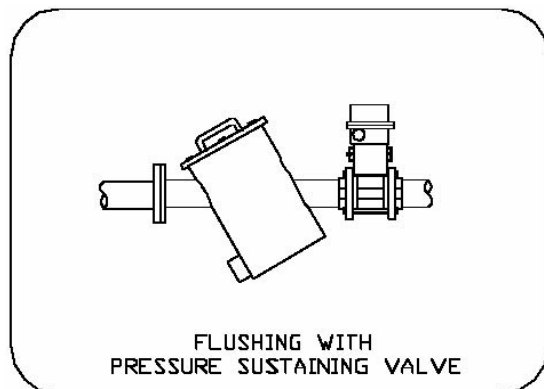

2. The required extra flow can be obtained by means of an expansion tank installed directly upstream of the filter inlet. The expansion tank would contain water at operating pressure to supply to the filter during the cleaning cycle.

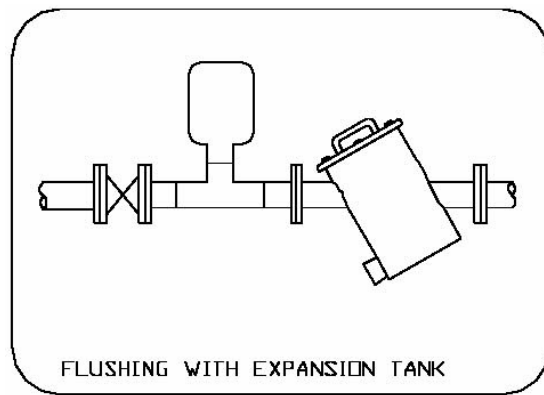

3. Another way to obtain supplemental flow is to add a water source to the inlet of the filter. The water source would be controlled with an actuated valve, opening during the cleaning cycle (see controller manual for wiring).

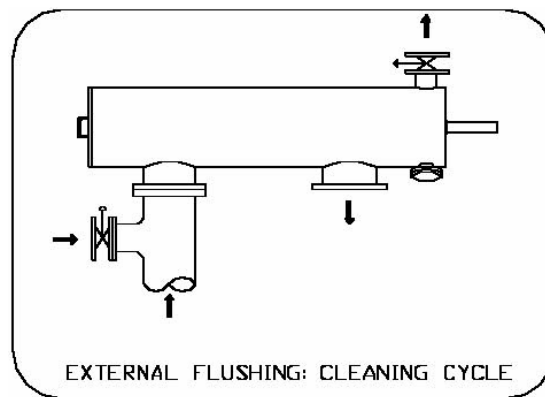
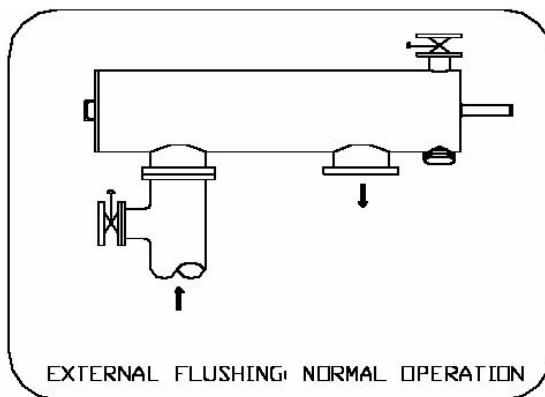

Appendix III System with Discharge to Atmosphere

If the filter freely discharges to the atmosphere, it is recommended that a control valve be installed at the filter outlet. In this case, the control valve at the outlet would be used to create back pressure on the system by reducing the flow across the filter. In addition, the discharge valve can be used as a pressure sustaining valve in cases where pressure is not adequate during backwash.

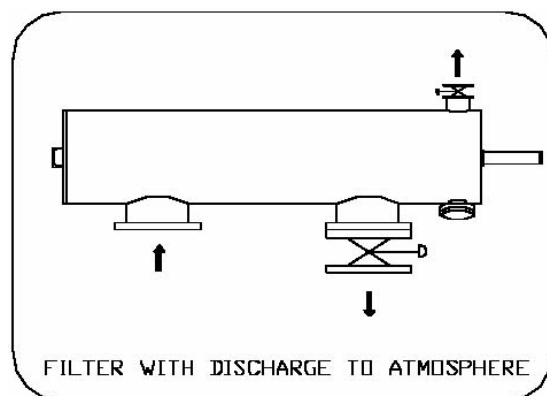

Appendix IV Piston

Due to longer screens on larger filters, it is necessary to employ a piston for the cleaning mechanism. The piston is used to control the linear movement of the dirt collector during cleaning cycles. This enables the dirt collector to clean the entire surface area of the screen in a spiral-downward movement. At the end of the cleaning cycle, the flush valve closes and the normal filtration process resumes. At the same time, the piston is pressurized, which pushes the dirt collector back into its original position, ready for the next cleaning cycle.

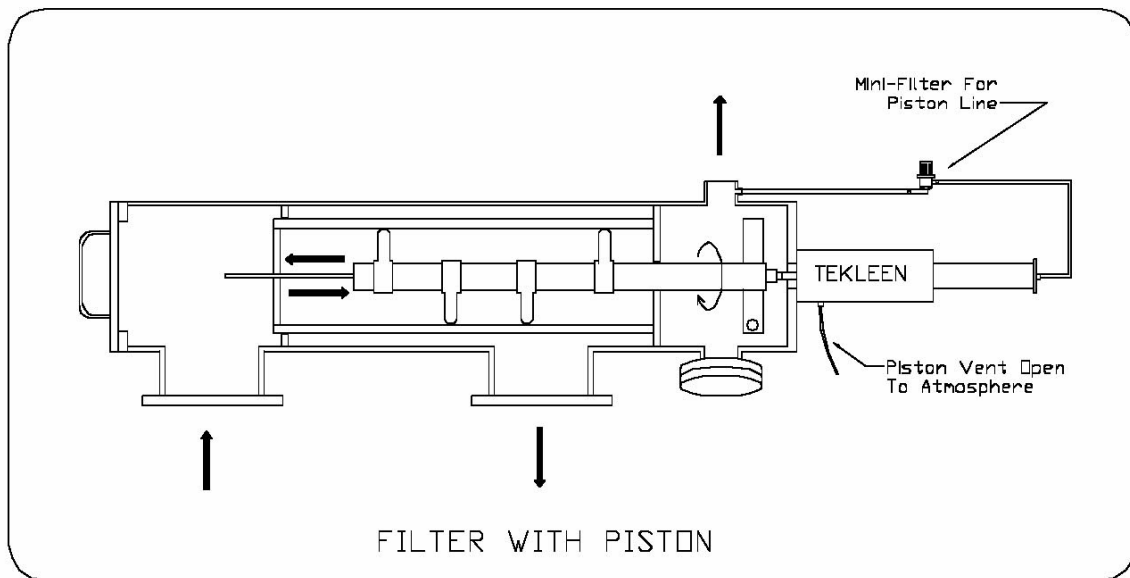

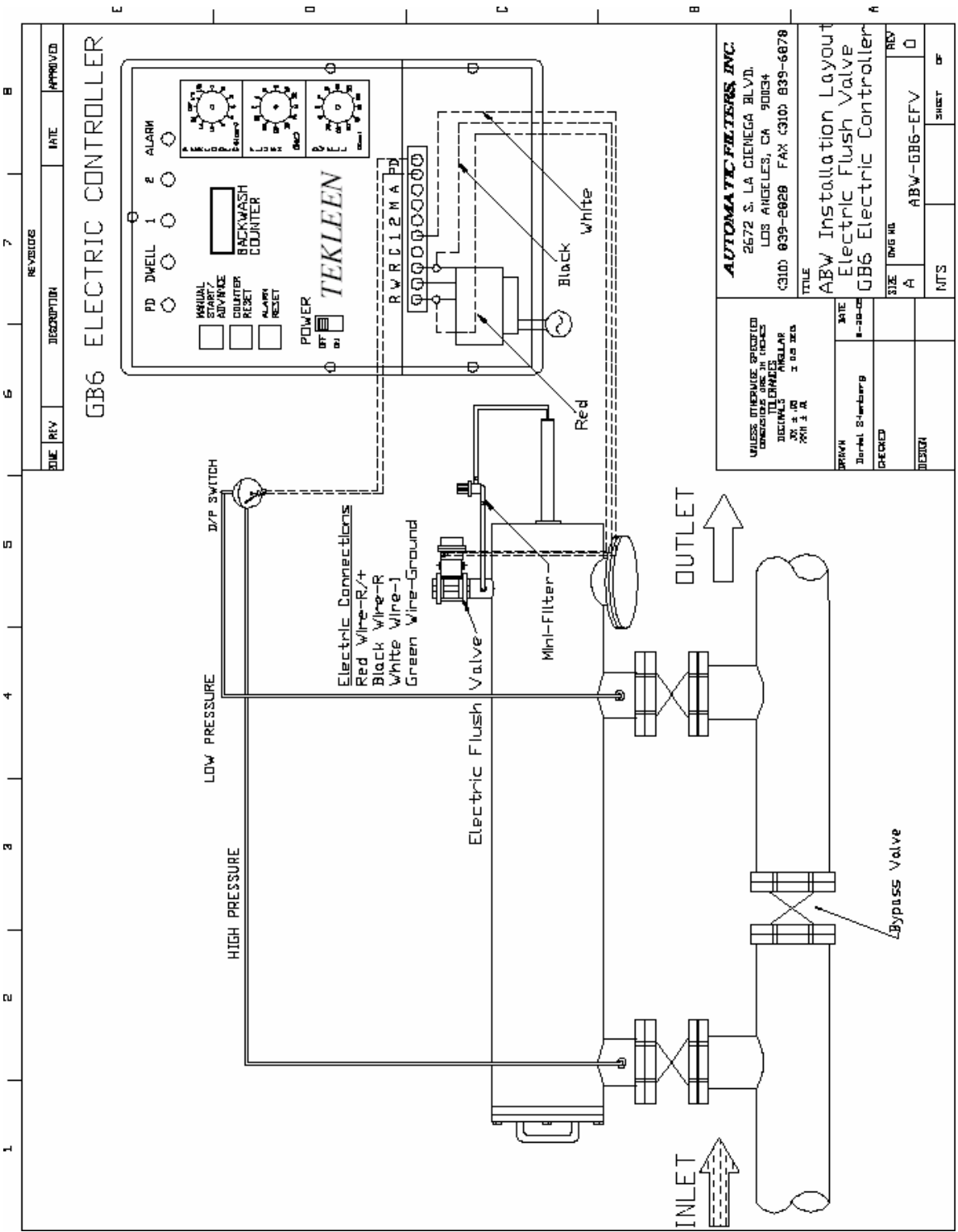

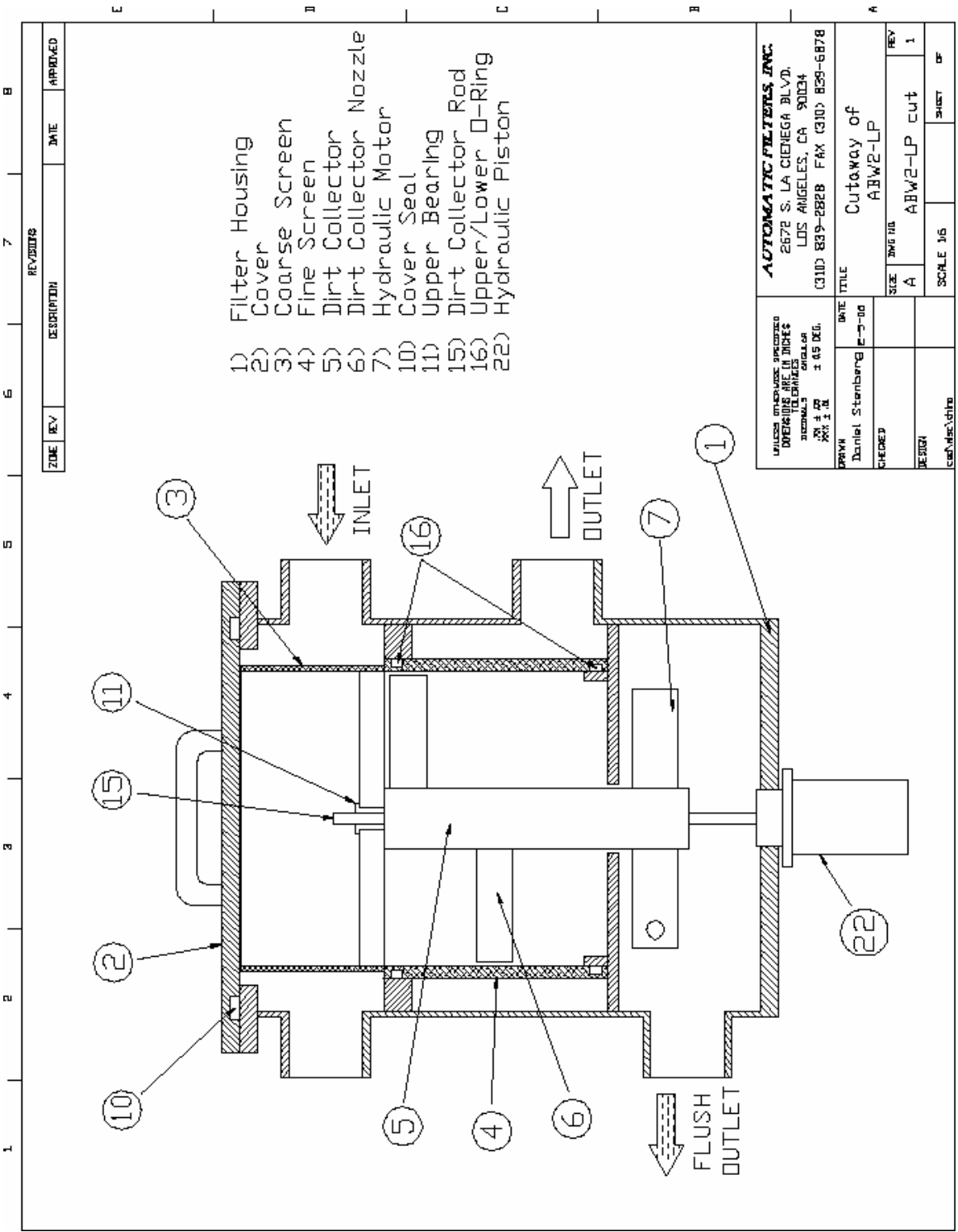

- 1) Filter Housing
- 2) Cover
- 3) Coarse Screen
- 4) Fine Screen
- 5) Dirt Collector
- 6) Dirt Collector Nozzle
- 7) Hydraulic Motor
- 10) Cover Seal
- 11) Upper Bearing
- 15) Dirt Collector Rod
- 16) Upper/Lower D-Ring
- 22) Hydraulic Piston

ZONE	REV	DESCRIPTION	DATE	APPROVED

AUTOMATIC FILTERS, INC. 2672 S. LA CIENEGA BLVD. LOS ANGELES, CA 90034 (310) 839-2828 FAX (310) 839-6878		TITLE Cutaway of ABW2-LP	
DESIGNED BY Daniel Sternberg	DATE 2-3-00	SCALE 3/8" = 1"	REV 1
CHECKED BY DEB24		SIZE A	ABW2-LP cut
DATE 12/24/04	SCALE 3/8"	SHEET OF	REV 1

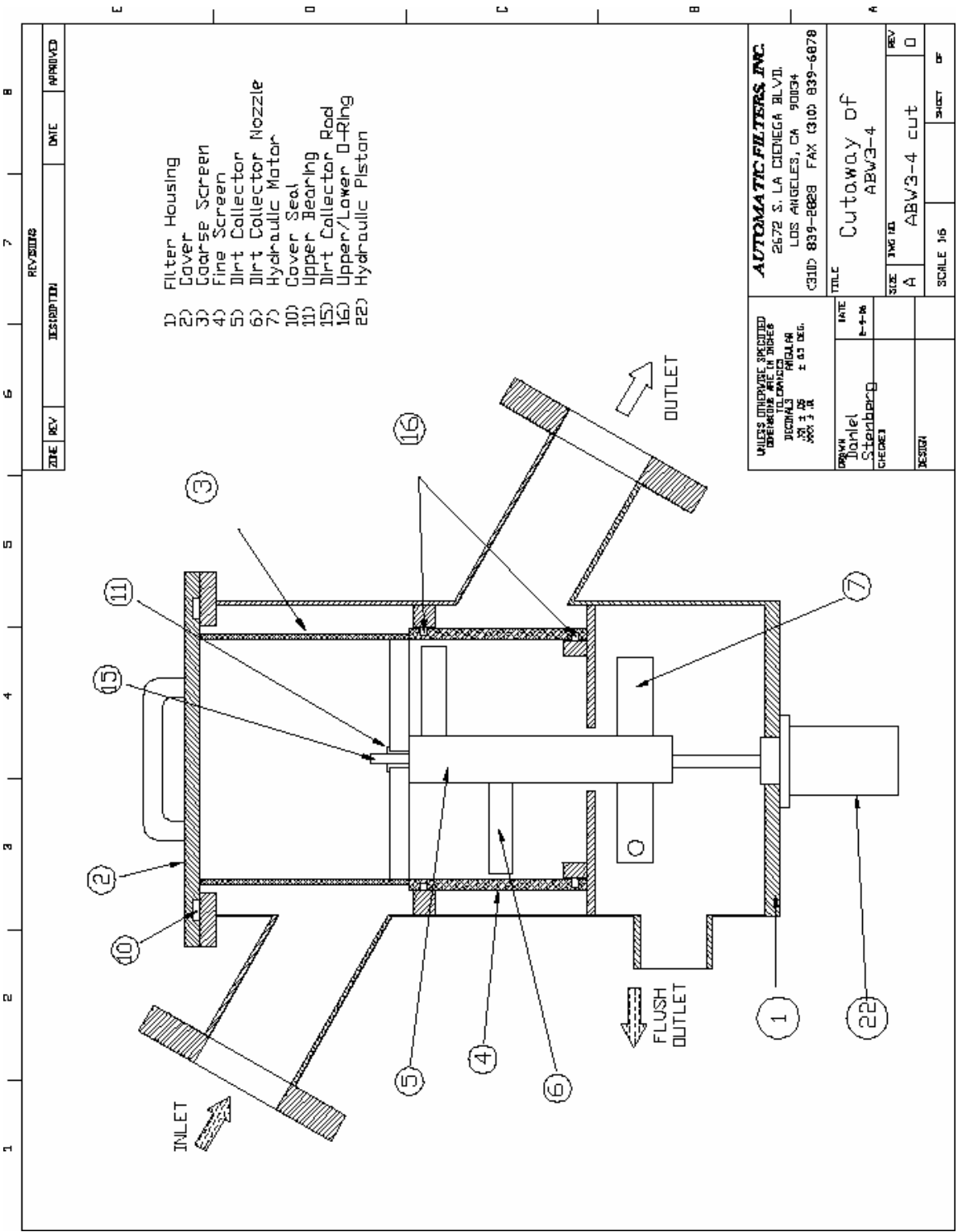

- 1) Filter Housing
- 2) Cover
- 3) Coarse Screen
- 4) Fine Screen
- 5) Dirt Collector
- 6) Dirt Collector Nozzle
- 7) Hydraulic Motor
- 10) Cover Seal
- 11) Upper Bearing
- 15) Dirt Collector Rod
- 16) Upper/Lower O-Ring
- 22) Hydraulic Piston

DATE	REV	DESCRIPTION	DATE	APPROVED

AUTOMATIC FILTERS, INC.
 2672 S. LA BIONEGA BLVD.
 LOS ANGELES, CA 90034
 CEHD: 839-2828 FAX (310) 839-6878

UNLESS OTHERWISE SPECIFIED
 DIMENSIONS ARE IN INCHES
 DECIMALS FRACTIONS
 .001 .005 ± .03 DEG.

DATE: 1-4-78
 DRAWN: Daniel Steinhilber
 CHECKED: [Signature]
 DESIGN: [Signature]

TITLE: Cutaway of ABWV3-4
 SIZE: 1 1/2" x 1 1/2" REV: 0
 A ABWV3-4 cut 0
 SCALE: 3/8" = 1" SHEET: OF

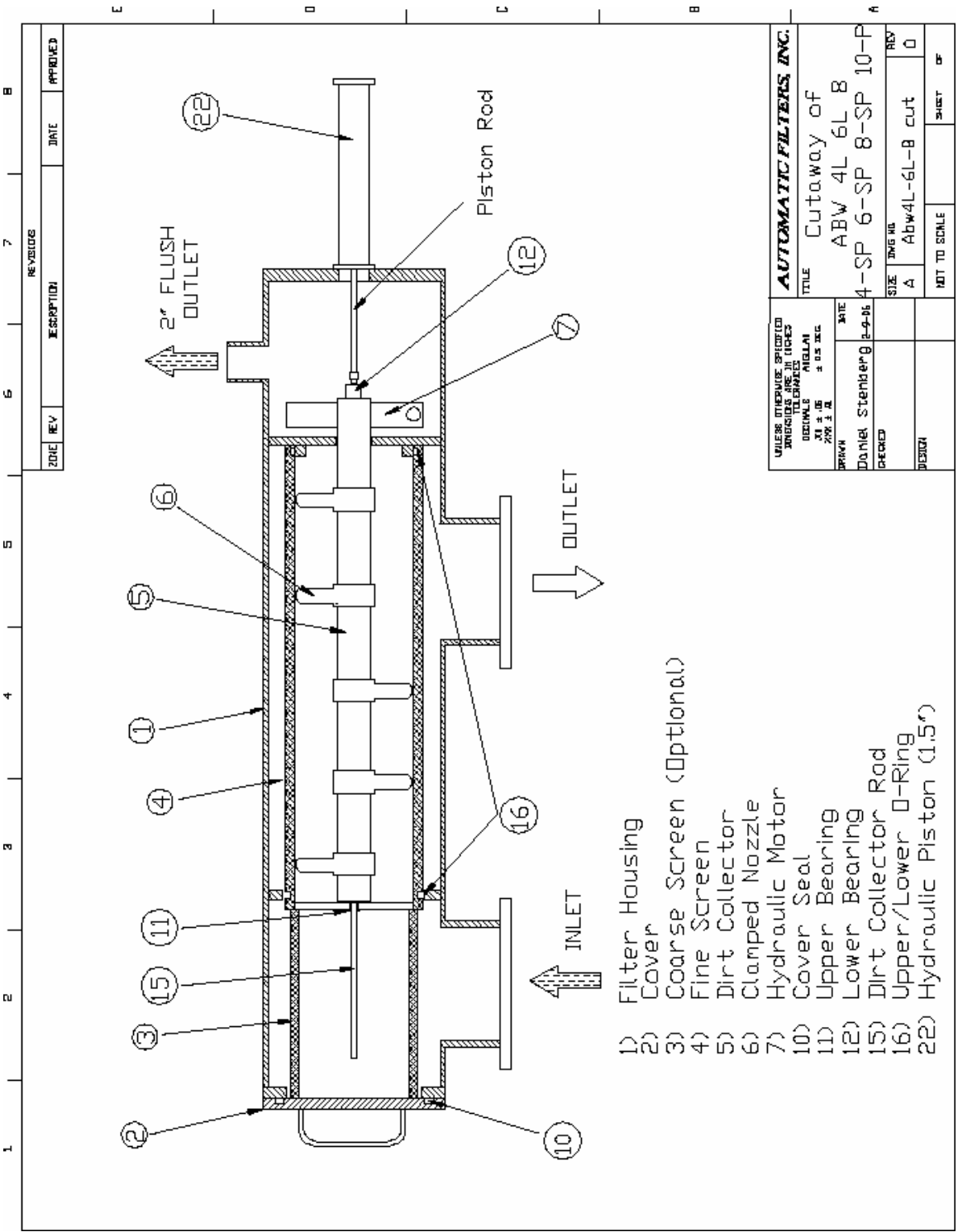

- 1) Filter Housing
- 2) Cover
- 3) Coarse Screen (Optional)
- 4) Fine Screen
- 5) Dirt Collector
- 6) Clamped Nozzle
- 7) Hydraulic Motor
- 10) Cover Seal
- 11) Upper Bearing
- 12) Lower Bearing
- 15) Dirt Collector Rod
- 16) Upper/Lower O-Ring
- 22) Hydraulic Piston (1.5")

UNLESS OTHERWISE SPECIFIED DIMENSIONS ARE IN INCHES DECIMALS AND FRACTIONS XX ± .05 XXX ± .1		DATE	REV
DRAWN		DATE	REV
CHECKED		DATE	REV
DESIGN		DATE	REV
AUTOMATIC FILTERS, INC. TITLE: Cutaway of ABW 4L 6L B 4-SP 6-SP 8-SP 10-P		SIZE	REV
		A	0
NOT TO SCALE		SHEET	OF

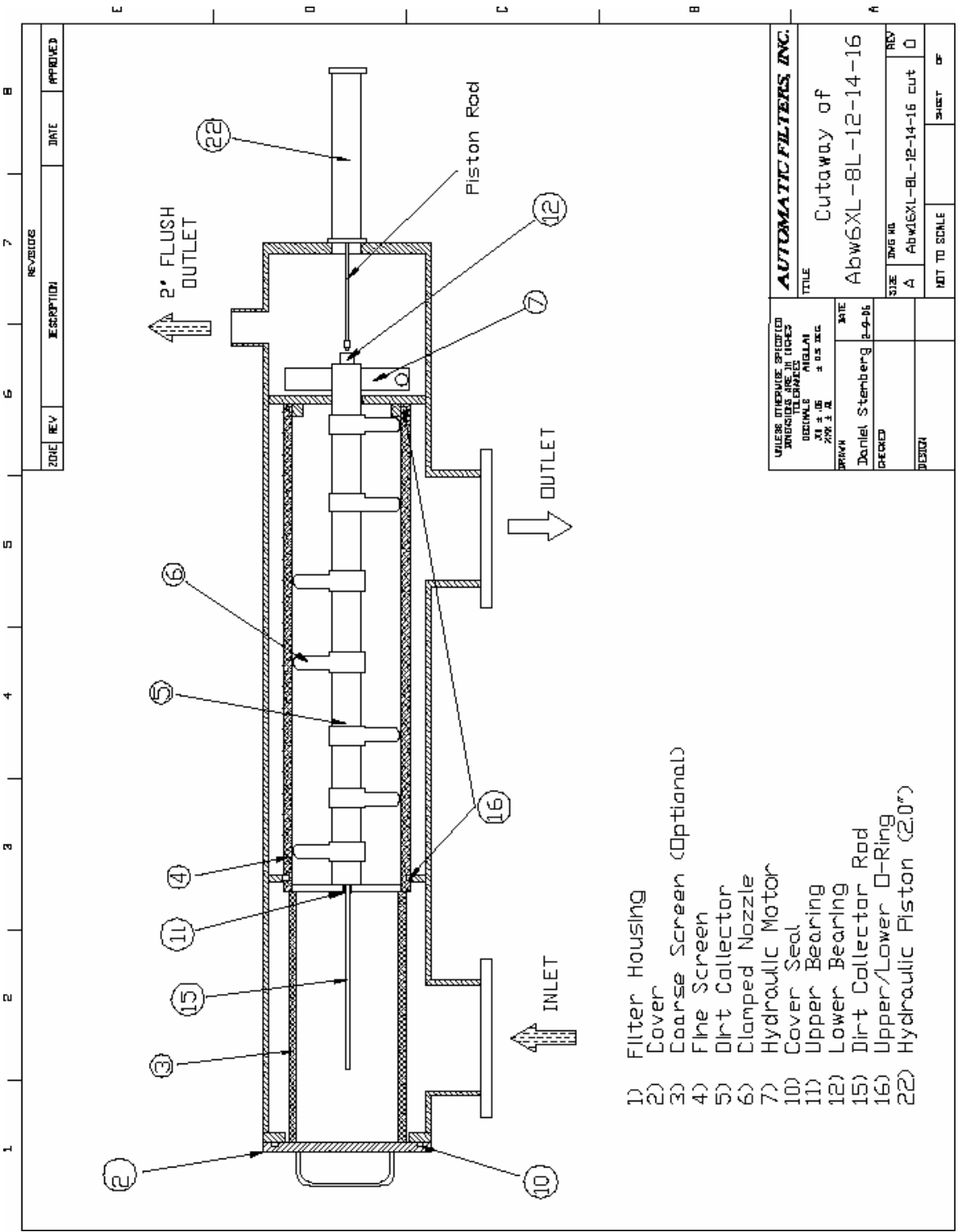

- 1) Filter Housing
- 2) Cover
- 3) Coarse Screen (Optional)
- 4) Fine Screen
- 5) Dirt Collector
- 6) Clamped Nozzle
- 7) Hydraulic Motor
- 10) Cover Seal
- 11) Upper Bearing
- 12) Lower Bearing
- 15) Dirt Collector Rod
- 16) Upper/Lower O-Ring
- 22) Hydraulic Piston (2.0")

UNLESS OTHERWISE SPECIFIED DIMENSIONS ARE IN INCHES DECIMALS AND FRACTIONS XX ± .05 XXX ± .1		DATE
DRAWN	Daniel Stenberg	8-2-06
CHECKED		
DESIGN		
AUTOMATIC FILTERS, INC.		
TITLE		
Cutaway of		
Abw6XL-8L-12-14-16		
SIZE	DWG NO.	REV.
A	Abw6XL-8L-12-14-16	cut 0
NOT TO SCALE		SHEET OF

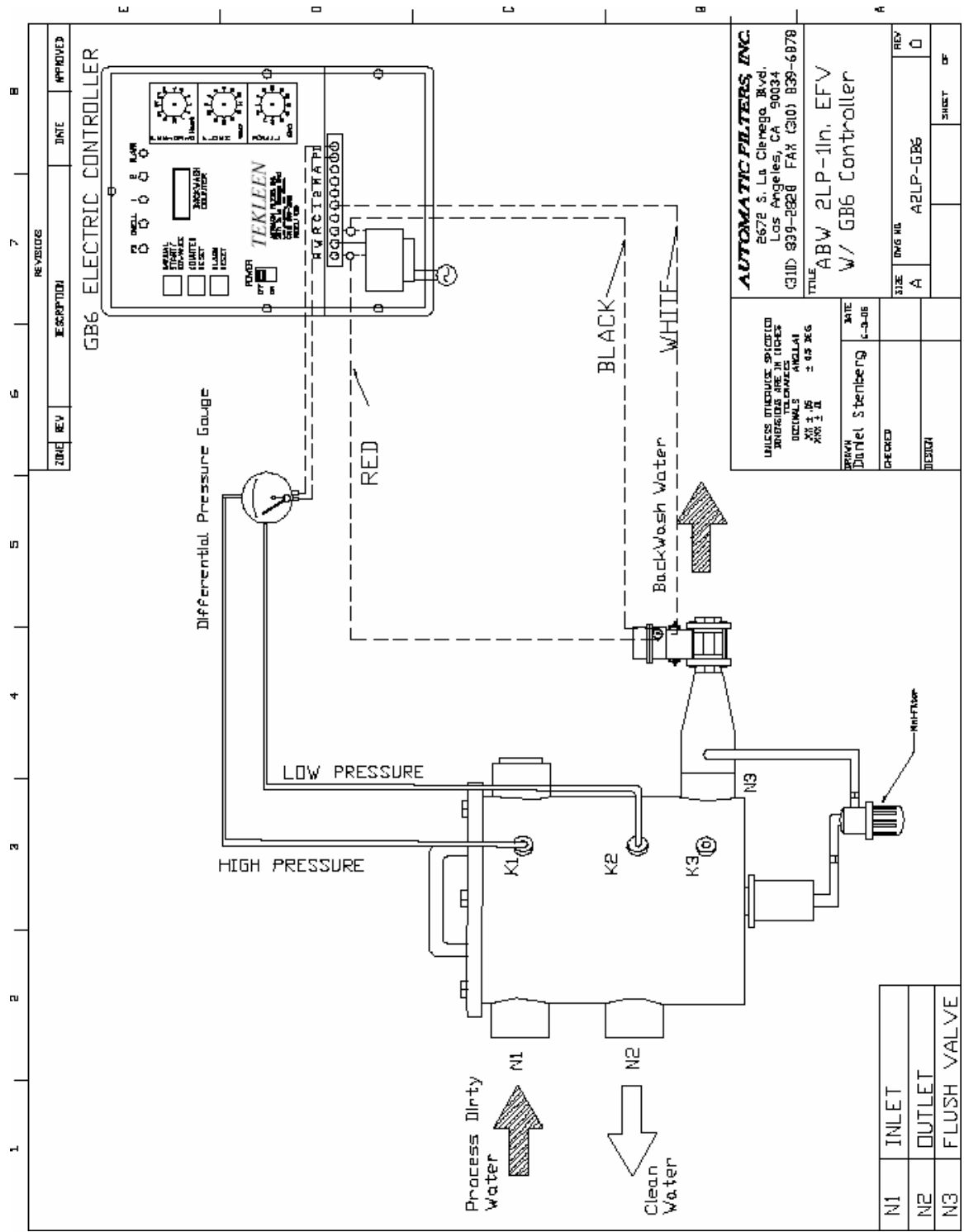

AUTOMATIC FILTERS, INC.
 2672 S. La. Clevege Blvd.
 Los Angeles, CA 90034
 (310) 839-2828 FAX (310) 839-6878

TITLE: ABW 2LP-1In. EFV
 W/ GB6 Controller

UNLESS OTHERWISE SPECIFIED
 DIMENSIONS ARE IN INCHES
 DECIMALS ANGULAR
 1/16 ± .015 1/8 ± .015 3/16 ± .02 1/4 ± .02 5/16 ± .02 3/8 ± .02 1/2 ± .02 5/8 ± .02 3/4 ± .02 1 ± .02 1 1/2 ± .02 2 ± .02 3 ± .02 4 ± .02 6 ± .02 8 ± .02 10 ± .02

DRAWN: Daniel Stenberg DATE: 4-3-06
 CHECKED: []
 DESIGN: []

SIZE	DWG NO.	REV
A	A2LP-GB6	0

SHEET OF

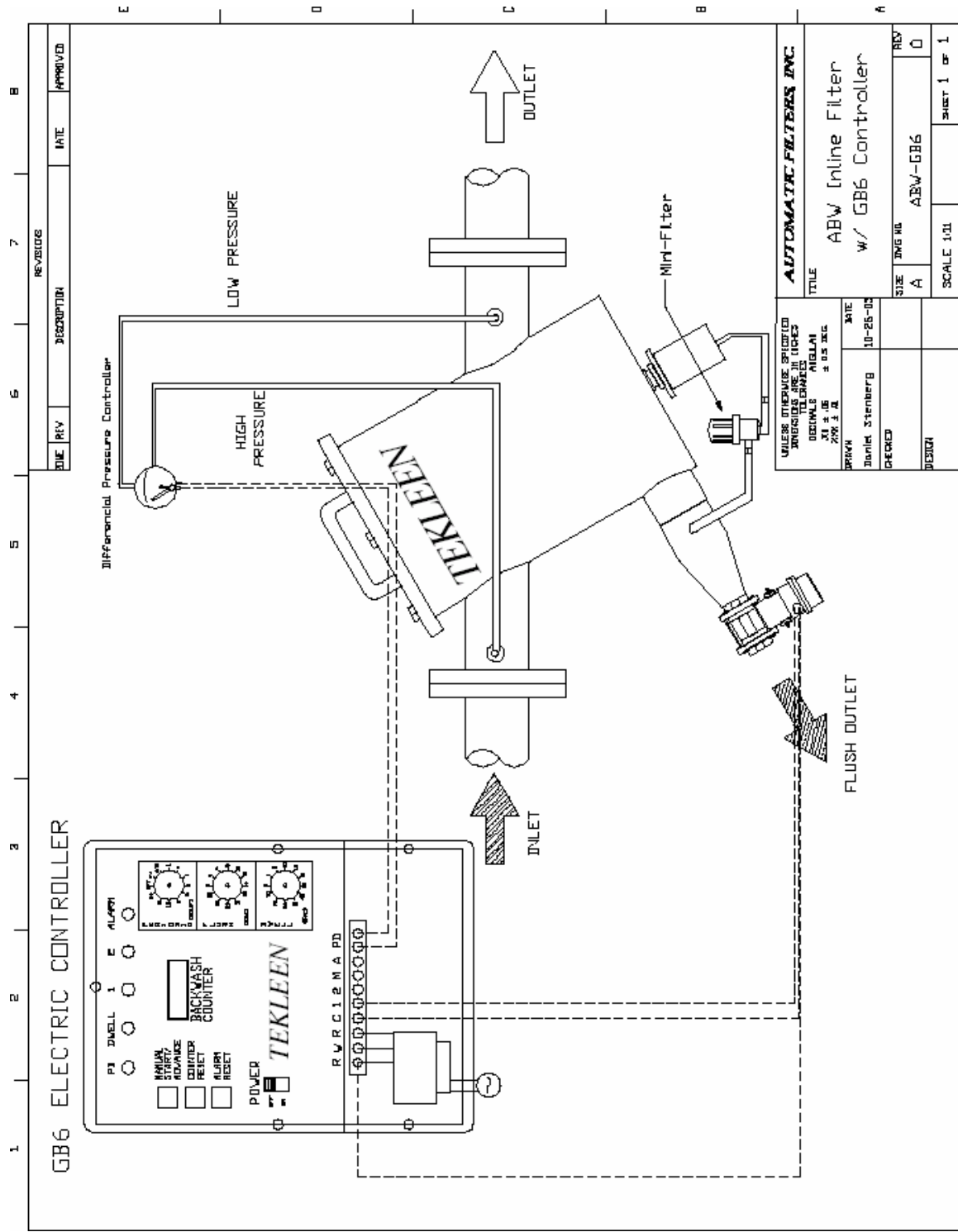

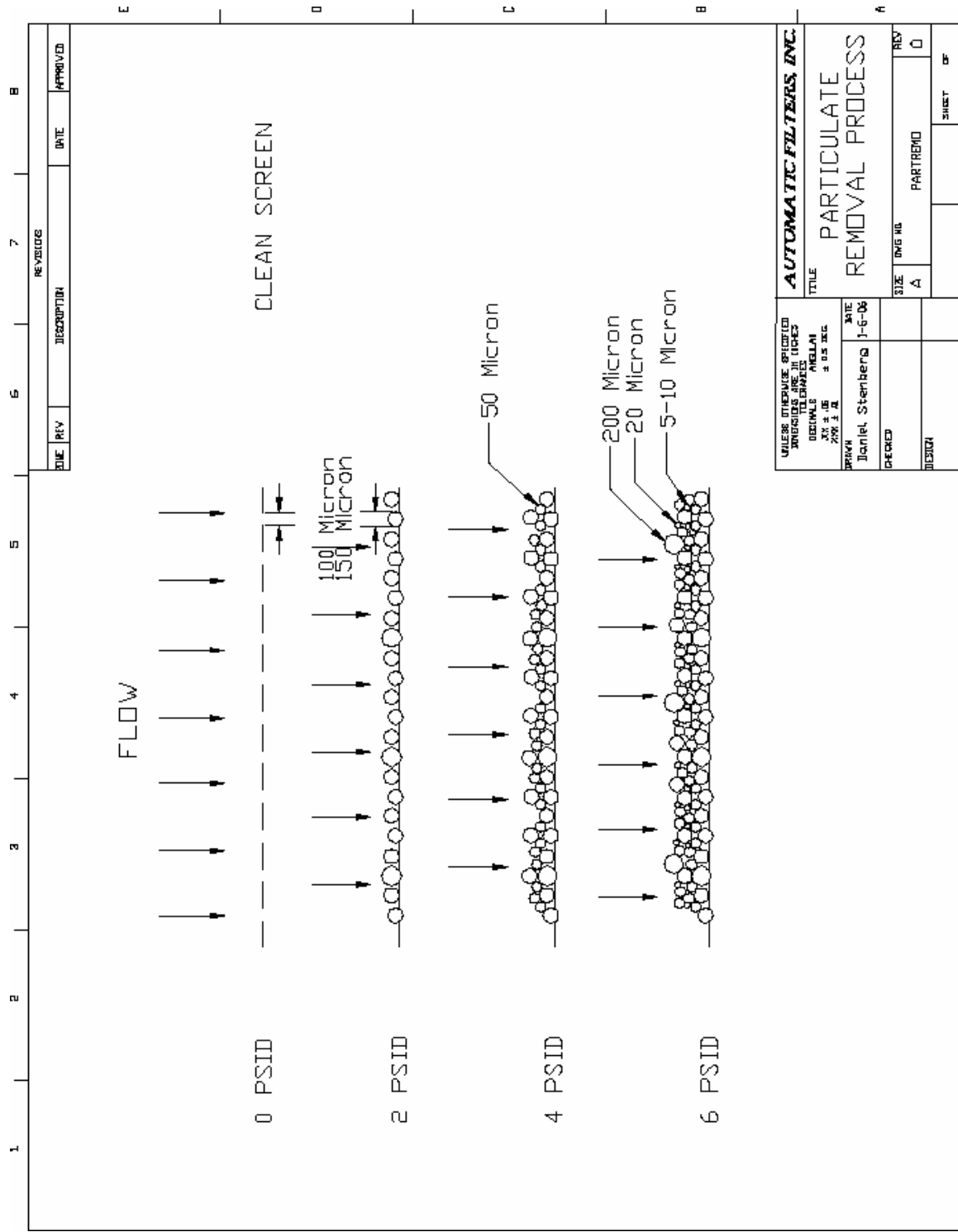

UNLESS OTHERWISE SPECIFIED DIMENSIONS ARE IN INCHES DECIMALS AND FRACTIONS XX ± .05 XXX ± .1 DRAWN Daniel Stenberg		AUTOMATIC FILTERS, INC. TITLE PARTICULATE REMOVAL PROCESS	
DATE	1-6-06	SIZE	ENG. NO.
CHECKED		A	PARTNO.
DESIGN		REV	0
		SHEET	OF

PRESSURE DROP DATA 1SQ FT.

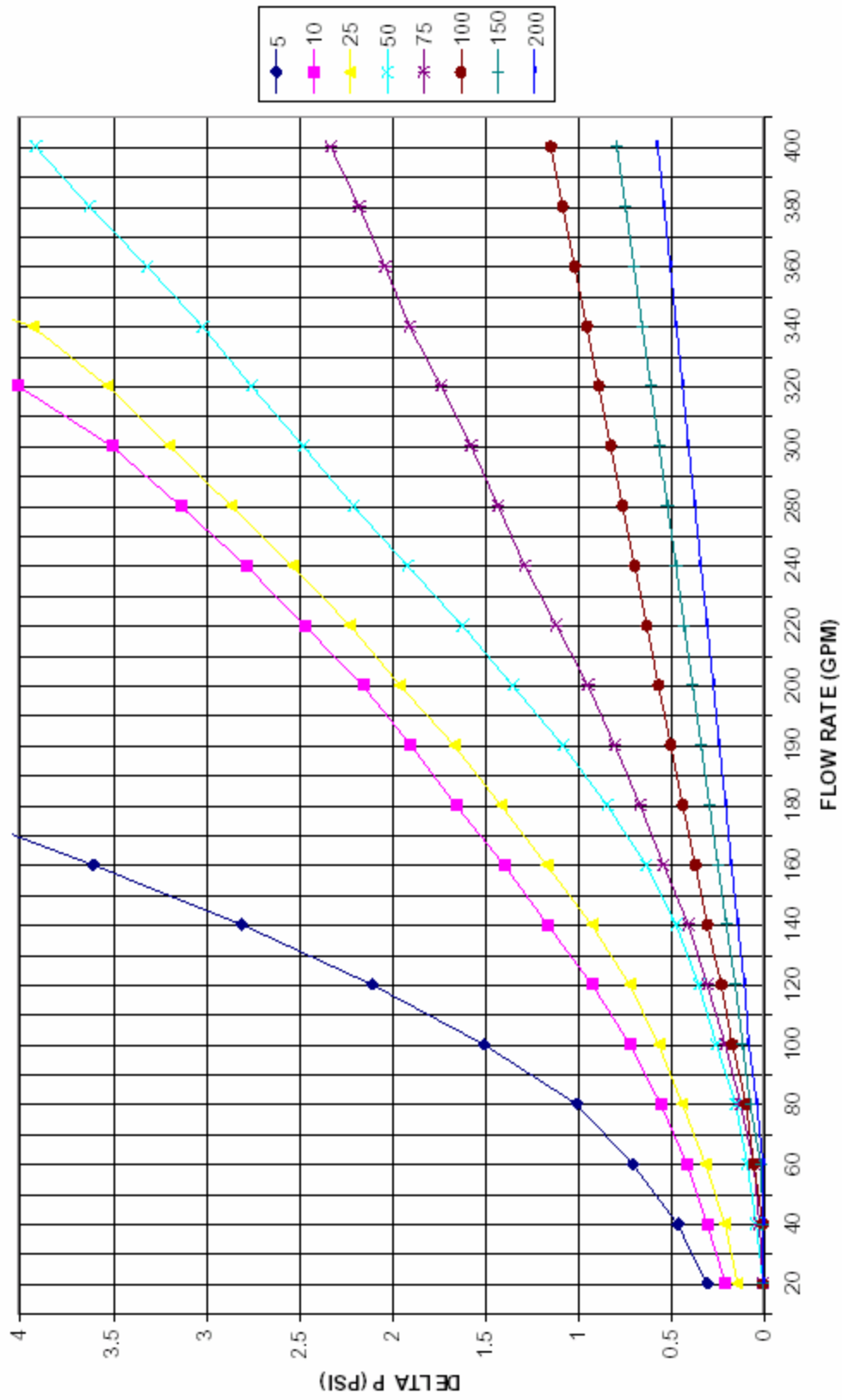

WARRANTY

Automatic Filters, Inc. (AFI) warrants its filters and controllers to be free from original defects for one year from the date of original sale. The manufacturer will replace, free of charge, any part found defective under normal use and service within the guarantee period, provided the product is installed, used, and maintained in accordance with good engineering practice and all applicable instructions or limitations issued by AFI. The manufacturer assumes no liability for incidental or consequential damage sustained in the adoption or use of our engineering data, service, or products. Liability is limited to the repair or replacement of the products. No agent or representative of AFI has the authority to waive or add to this agreement. Altered products or use of products in a manner not intended shall void this warranty. All warranty claims must be sent along with the defective product, freight prepaid to AFI at its business address. All warranty shipments are for the account of the buyer. The warranty period shall be 12 months from the date of shipment to the client.