

REVISIONS				
ZONE	REV	DESCRIPTION	DATE	APPROVED

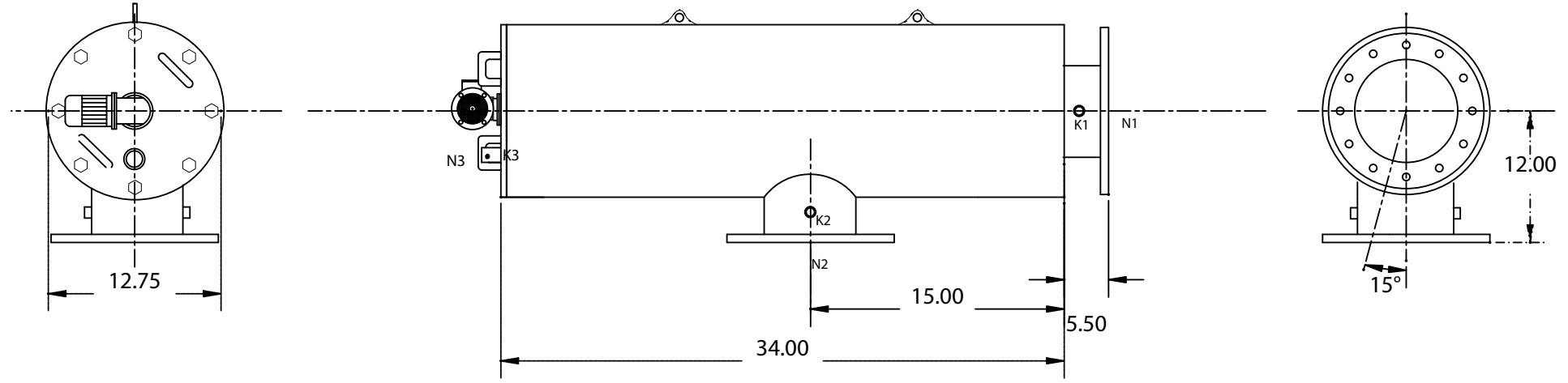

TECHNICAL DATA

Flow Rate	Max. 800 GPM
Screen Size	___ Micron
Screen Area	5.0 Sq.Ft.
Working Temp.	200 deg. F
Working Pressure	150 PSI
Empty Weight	200 lbs.
Full Weight	___ lbs.

UNLESS OTHERWISE SPECIFIED
DIMENSIONS ARE IN INCHES
TOLERANCES
DECIMALS ANGULAR
.XX + .Q5 ± 0.5 DEG.
.XXX + .Q1

AUTOMATIC FILTERS, INC.
2672 S. LA CIENEGA BLVD.
LOS ANGELES, CA 90034
(310) 839-2828 FAX (310) 839-6878

NOZZLE	CONNECTION	TYPE OF CONNECTION	SIZE	RATING
K1	Hi. Press. Conn.	Threaded	1/4" NPT(2)	150 lbs. F.F.
K2	Low Press. Conn.	Threaded	1/4" NPT(2)	
K3	Flushoutlet Conn.	Threaded	1/4" NPT(2)	
N1	Inlet	Flanged	8" ASA	
N2	Outlet	Flanged	8" ASA	
N3	Flushoutlet	Threaded	2" NPT	

DRAWN Daniel Stenberg		DATE 2-17-06	TITLE CSB 8		
CHECKED					
DESIGN			SIZE A	DWG NO. CSB 8	REV 0
scale 1:14			SHEET OF		