

FRONT VIEW

REVISIONS				
REV.	ZONE	DESCRIPTION	DATE	INITIAL

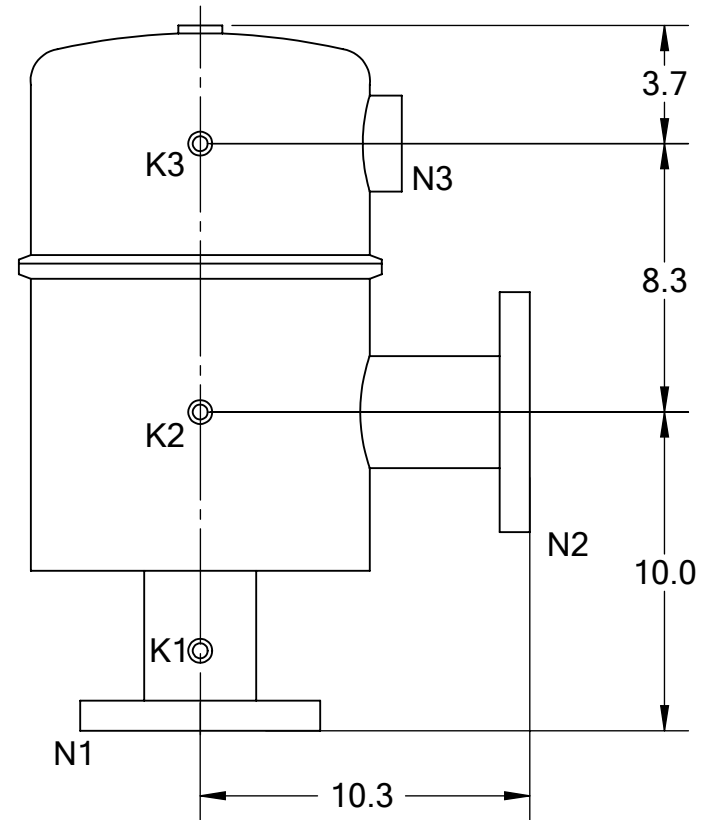

SIDE VIEW

TECHNICAL DATA

FLOW RATE	MAX. 350 GPM (80 m ³ /hr)
SCREEN SIZE	___ MICRON
SCREEN AREA	1.5 SQ. FEET
MAXIMUM TEMPERATURE	MAX. 200 °F
MAXIMUM PRESSURE	MAX. 150 PSI
EMPTY WEIGHT	~90 LBS.
FULL WEIGHT	~165 LBS.

NOZZLE	CONNECTION	TYPE	SIZE	RATING
K1	HIGH PRESSURE CONN.	THREADED	1/4" NPT(2)	CLASS #150 F.F.S.O.
K2	LOW PRESSURE CONN.	THREADED	1/4" NPT	
K3	HYDRAULIC CONN.	THREADED	1/4" NPT	CLASS #150 F.F.S.O.
N1	INLET	FLANGED	3" ASA	
N2	OUTLET	FLANGED	3" ASA	
N3	FLUSH OUTLET	THREADED	2" NPT	

TOLERANCES (UNLESS OTHERWISE SPECIFIED)

FRAC. ±1/16
 .X ±.1
 .XX ±.05
 .XXX ±.010

ANGLE ±1°

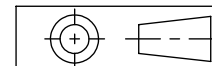

MATERIAL: SST

DRAWN BY: S. PERKINSON

DATE: 11/14/11

SCALE: 1:6

SHEET: 1 OF 1

TEKLEEN®
Automatic Filters Inc.
 2672 S. LA CIENEGA BLVD.
 LOS ANGELES, CA 90034
 MAIN: (310) 839-2828
 FAX: (310) 839-6878

TITLE: MTF3 FILTER, CUT DRAWING

DRAWING NUMBER	REV
MTF-3-CUT-01	N/A