

REVISIONS				
REV.	ZONE	DESCRIPTION	DATE	INITIAL

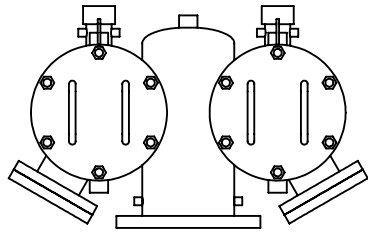

FRONT VIEW

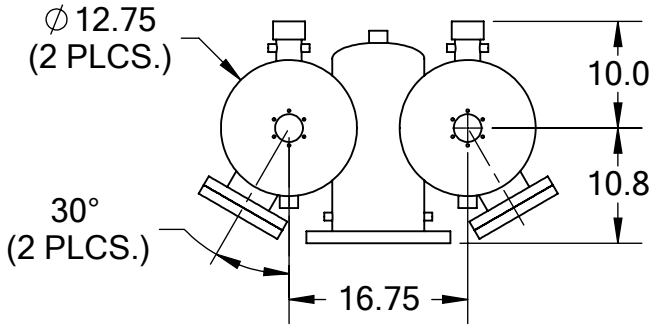

BACK VIEW

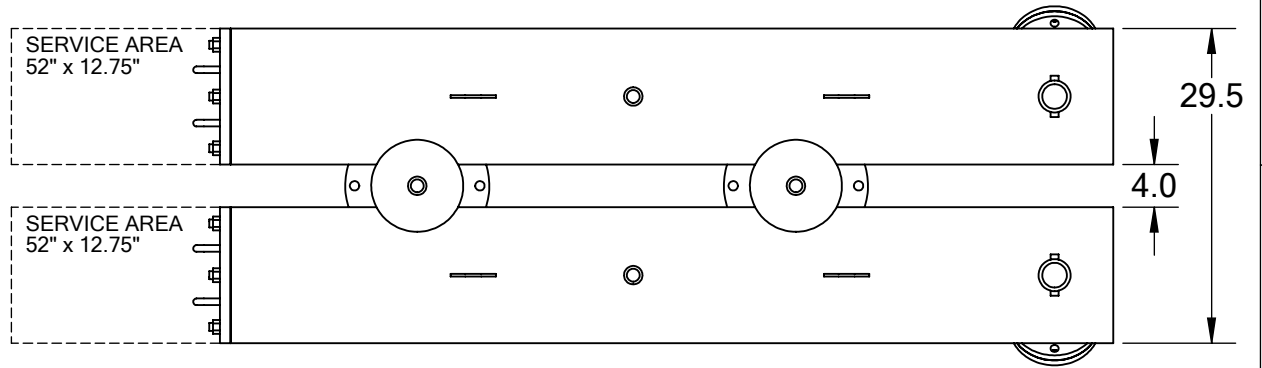

TOP VIEW

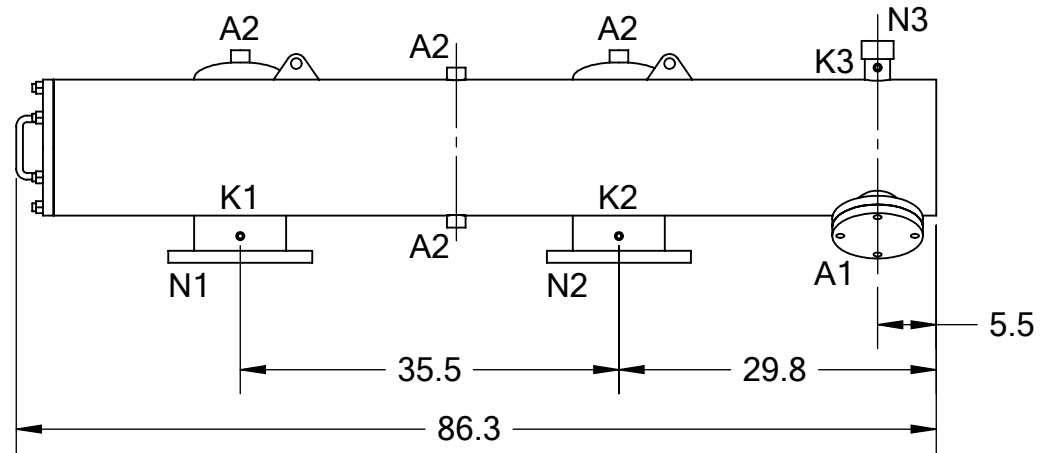

SIDE VIEW

TECHNICAL DATA

FLOW RATE	MAX. 2,500 GPM (568 m ³ /hr)
SCREEN SIZE	--- MICRON
SCREEN AREA	16.0 SQ. FT. (2 x 8.0 SQ. FT.)
MAXIMUM TEMPERATURE	200 °F
MAXIMUM PRESSURE	150 PSI
EMPTY WEIGHT	~1,000 LBS.
FULL WEIGHT	~1,800 LBS.

NOZZLE	CONNECTION	TYPE	SIZE	RATING	TOLERANCES (UNLESS OTHERWISE SPECIFIED)		2672 S. LA CIENEGA BLVD. LOS ANGELES, CA 90034 MAIN: (310) 839-2828 FAX: (310) 839-6878
A1	SERVICE PORT	FLANGED	3.5" ASA	CL. #150 F.F. w/ Blind	FRAC. ±1/16	ANGLE ±1°	
A2	PRESSURE RELEASE	THREADED	1" NPT(6)		.X ±.1		
K1	HIGH PRESSURE CONN.	THREADED	1/4" NPT(2)	CLASS #150 F.F.S.O. CLASS #150 F.F.S.O.	.XX ±.05	MATERIAL: SST	DRAWING NUMBER
K2	LOW PRESSURE CONN.	THREADED	1/4" NPT(2)		.XXX ±.010		
K3	HYDRAULIC CONN.	THREADED	1/4" NPT(4)		DATE: 09/28/11		ABW-8TLP-CUT-01
N1	INLET	FLANGED	8" ASA		SCALE: 1:18	SHEET: 1 OF 1	N/A
N2	OUTLET	FLANGED	8" ASA				
N3	FLUSH OUTLET	THREADED	2" NPT(2)				