

REVISIONS				
REV.	ZONE	DESCRIPTION	DATE	INITIAL

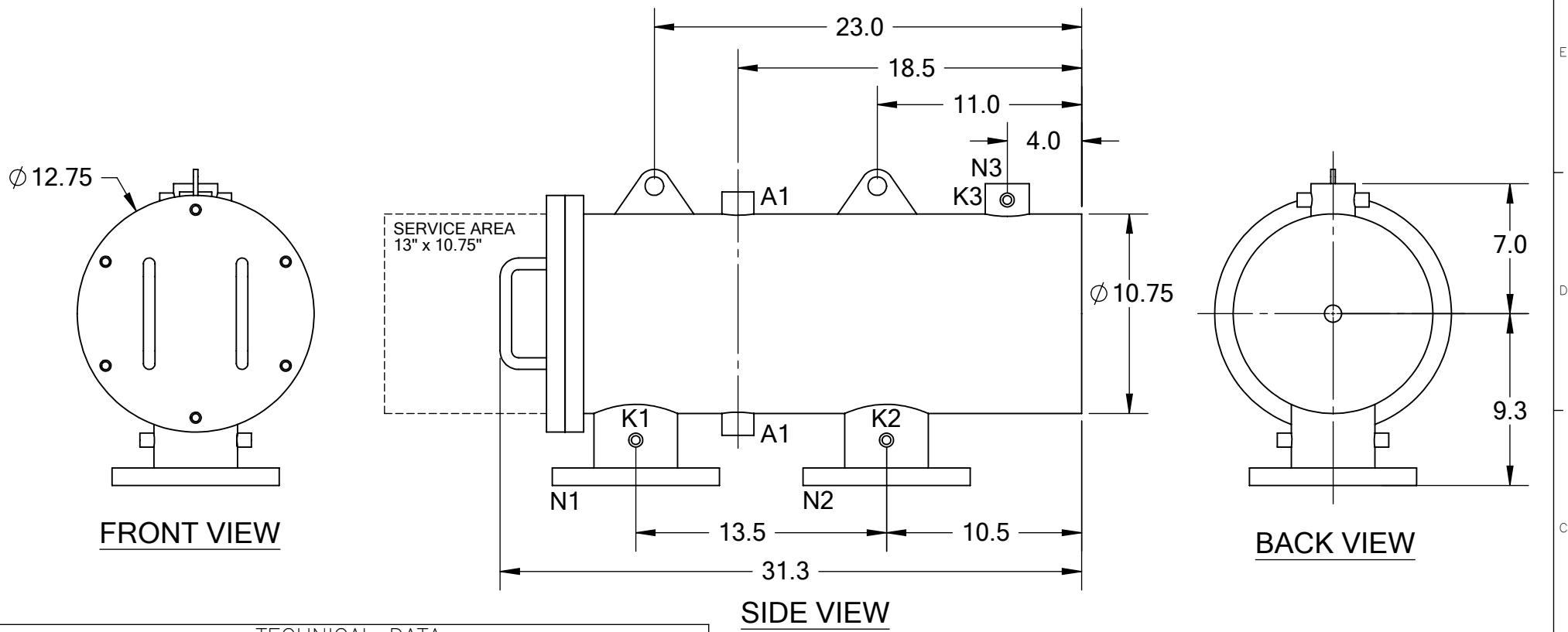

TECHNICAL DATA

FLOW RATE	MAX. 300 GPM (68 m ³ /hr)
SCREEN SIZE	____ MICRON
SCREEN AREA	1.4 SQ. FEET
WORKING TEMPERATURE	MAX. 200 °F
WORKING PRESSURE	MAX. 150 PSI
EMPTY WEIGHT	~170 LBS.
FULL WEIGHT	~270 LBS.

NOZZLE	CONNECTION	TYPE	SIZE	RATING
A1	PRESSURE RELEASE	THREADED	1" NPT(2)	CLASS #150 F.F.S.O. CLASS #150 F.F.S.O.
K1	HIGH PRESSURE CONN.	THREADED	1/4" NPT(2)	
K2	LOW PRESSURE CONN.	THREADED	1/4" NPT(2)	
K3	HYDRAULIC CONN.	THREADED	1/4" NPT(2)	
N1	INLET	FLANGED	4" ASA	
N2	OUTLET	FLANGED	4" ASA	
N3	FLUSH OUTLET	THREADED	2" NPT	

TOLERANCES
(UNLESS OTHERWISE SPECIFIED)

FRAC. ±1/16
.X ±.1
.XX ±.05
.XXX ±.010

ANGLE ±1°

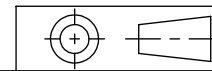

MATERIAL: SST

DRAWN BY: S. PERKINSON

DATE: 09/20/11

SCALE: 1:8

SHEET: 1 OF 1

TEKLEEN
Automatic Filters Inc.
2672 S. LA CIENEGA BLVD.
LOS ANGELES, CA 90034
MAIN: (310) 839-2828
FAX: (310) 839-6878

TITLE: ABW4-P FILTER, CUT DRAWING

DRAWING NUMBER: ABW-4P-CUT-01
REV: N/A