

REVISIONS				
REV.	ZONE	DESCRIPTION	DATE	INITIAL

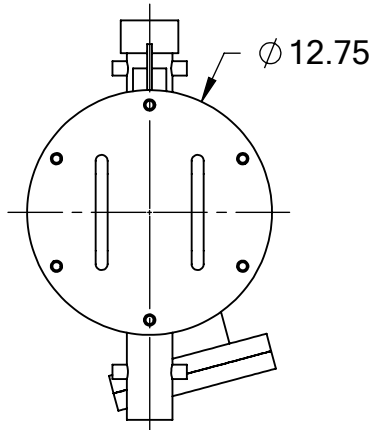

**FRONT VIEW**

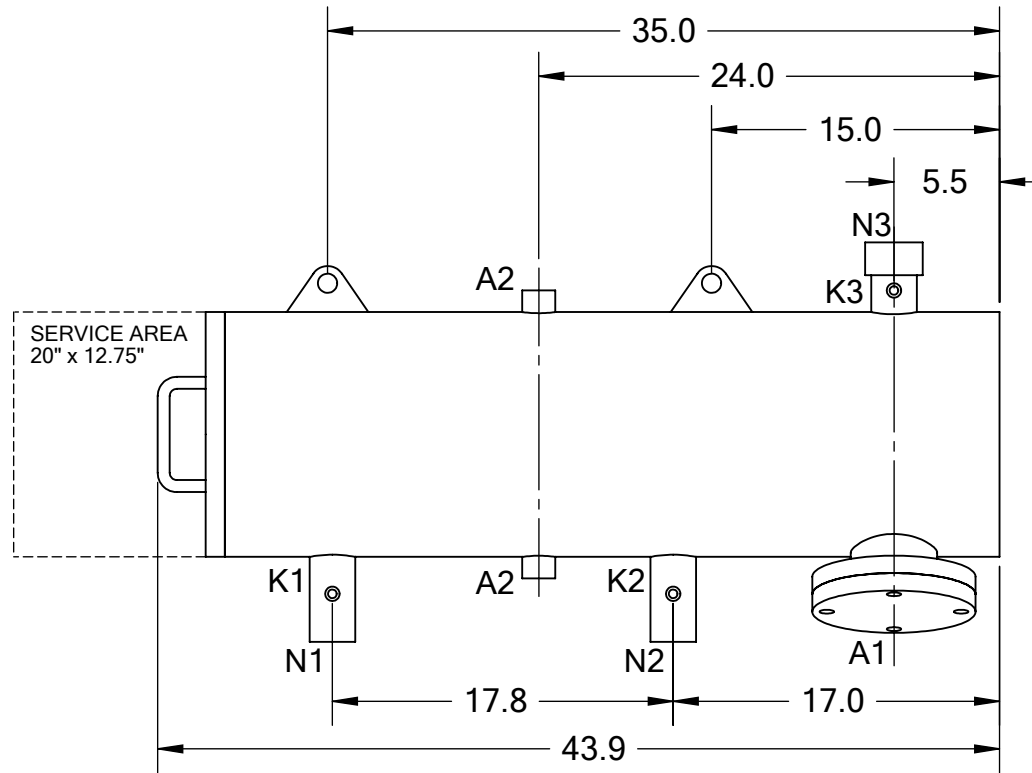

**SIDE VIEW**

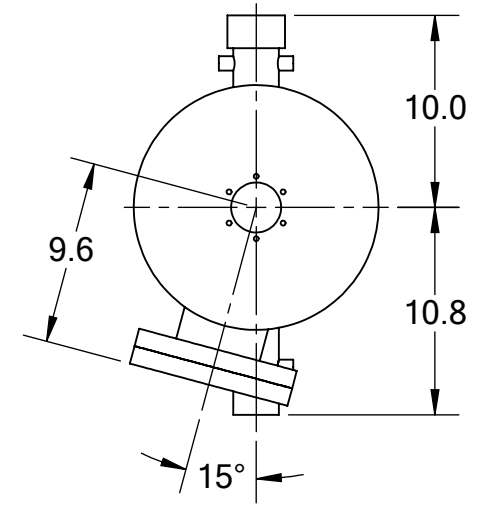

**BACK VIEW**

**TECHNICAL DATA**

FLOW RATE	MAX. 300 GPM (68 m <sup>3</sup> /hr)
SCREEN SIZE	___ MICRON
SCREEN AREA	2.5 SQ. FEET
WORKING TEMPERATURE	MAX. 200 °F
WORKING PRESSURE	MAX. 150 PSI
EMPTY WEIGHT	~225 LBS.
FULL WEIGHT	~425 LBS.

NOZZLE	CONNECTION	TYPE	SIZE	RATING
A1	SERVICE PORT	FLANGED	3.5" ASA	CL. #150 F.F. w/ Blind
A2	PRESSURE RELEASE	THREADED	1" NPT(2)	
K1	HIGH PRESSURE CONN.	THREADED	1/4" NPT(2)	
K2	LOW PRESSURE CONN.	THREADED	1/4" NPT(2)	
K3	HYDRAULIC CONN.	THREADED	1/4" NPT(2)	
N1	INLET	THREADED	2" NPT	
N2	OUTLET	THREADED	2" NPT	
N3	FLUSH OUTLET	THREADED	2" NPT	

**TOLERANCES (UNLESS OTHERWISE SPECIFIED)**

FRAC. ±1/16  
.X ±.1  
.XX ±.05  
.XXX ±.010

ANGLE ±1°

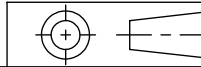

**MATERIAL:** SST

**DRAWN BY:** S. PERKINSON

**DATE:** 08/26/11

**SCALE:** 1:10 **SHEET:** 1 OF 1

**TEKLEEN**  
Automatic Filters Inc.  
2672 S. LA CIENEGA BLVD.  
LOS ANGELES, CA 90034  
MAIN: (310) 839-2828  
FAX: (310) 839-6878

**TITLE:**  
ABW2-XLP FILTER,  
CUT DRAWING

**DRAWING NUMBER** ABW-2XLP-CUT-01  
**REV** N/A