

REVISIONS				
REV.	ZONE	DESCRIPTION	DATE	INITIAL

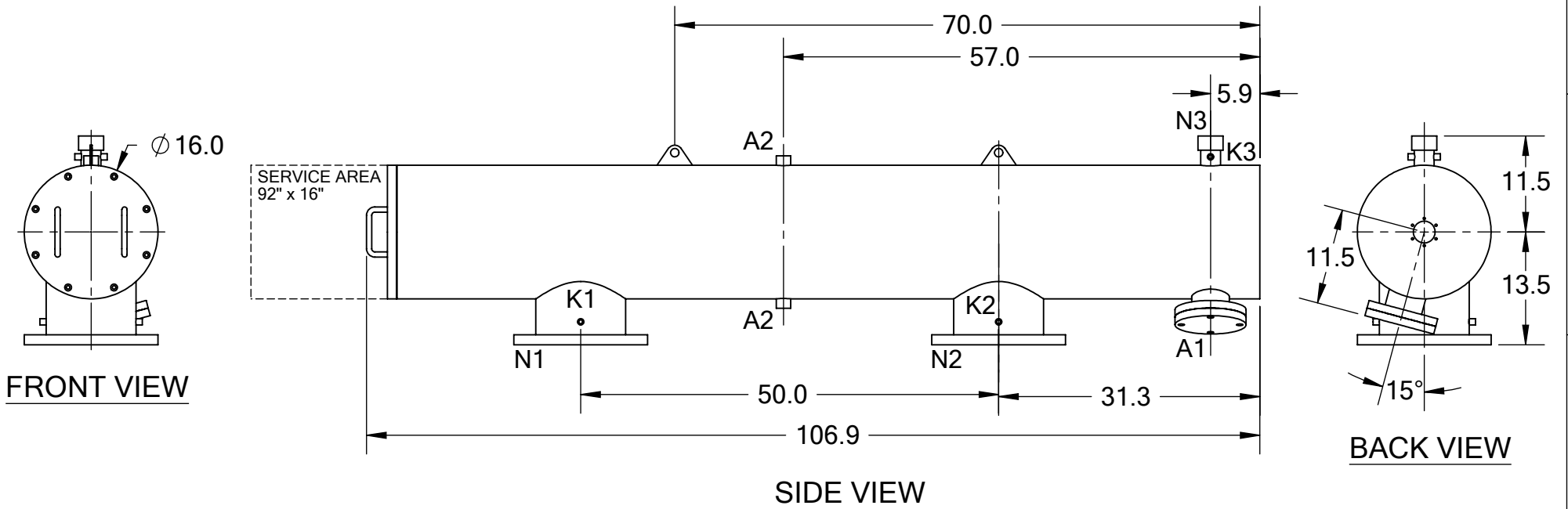

TECHNICAL DATA

FLOW RATE	MAX. 2,630 GPM (597 m <sup>3</sup> /hr)
SCREEN SIZE	____ MICRON
SCREEN AREA	11.0 SQ. FEET
WORKING TEMPERATURE	MAX. 200 °F
WORKING PRESSURE	MAX. 150 PSI
EMPTY WEIGHT	~650 LBS.
FULL WEIGHT	~1,400 LBS.

NOZZLE	CONNECTION	TYPE	SIZE	RATING
A1	SERVICE PORT	FLANGED	3.5" ASA	CL. #150 F.F. w/ Blind
A2	PRESSURE RELEASE	THREADED	1" NPT(2)	
K1	HIGH PRESSURE CONN.	THREADED	1/4" NPT(2)	CLASS #150 F.F.S.O.
K2	LOW PRESSURE CONN.	THREADED	1/4" NPT(2)	
K3	HYDRAULIC CONN.	THREADED	1/4" NPT(2)	CLASS #150 F.F.S.O.
N1	INLET	FLANGED	10" ASA	
N2	OUTLET	FLANGED	10" ASA	
N3	FLUSH OUTLET	THREADED	2" NPT	

TOLERANCES (UNLESS OTHERWISE SPECIFIED)

FRAC. ±1/16	ANGLE ±1°
.X ±.1	
.XX ±.05	
.XXX ±.010	

MATERIAL: SST
DRAWN BY: S. PERKINSON
DATE: 07/06/11
SCALE: 1:18
SHEET: 1 OF 1

**TEKLEEN**  
Automatic Filters Inc.  
2672 S. LA CIENEGA BLVD.  
LOS ANGELES, CA 90034  
MAIN: (310) 839-2828  
FAX: (310) 839-6878

TITLE: ABW10-LP FILTER, CUT DRAWING	
DRAWING NUMBER ABW-10LP-CUT-01	REV N/A